



















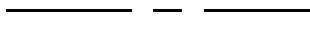
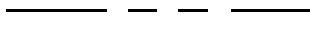
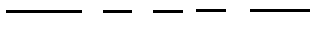
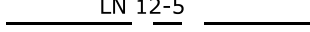

APPENDIX G

MANITOBA HYDRO STREET LIGHT STANDARDS

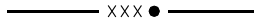
| EQUIPMENT (CONTINUED) | | CABLES (CONTINUED) | | | |
|---|---|--|--|---|-----------------------------|
| SYMBOL | DESCRIPTION | SYMBOL | DESCRIPTION | | |
|  | UNDERPASS LUMINAIRE (NUMBER OF UNITS x WATTAGE) | RI/PVCJ | RUBBER INSULATED, POLYVINYL CHLORIDE JACKET | | |
|  | HIMAST LIGHTING WITH 3 LUMINAIRES (WATTAGE) | XLPE | CROSS LINKED POLYETHYLENE | | |
|  | FAULTED CIRCUIT INDICATOR | TRXLPE | TREE RETARDANT XLPE | | |
|  | LIGHTNING ARRESTER | CTS | CORRUGATED TAPE SHIELD | | |
|  | GROUND ROD | CN, C/N | CONCENTRIC NEUTRAL | | |
|  | HYDRANT GROUND | CNJ | CONCENTRIC NEUTRAL WITH JACKET | | |
|  | LOAD BREAK FUSE | PEI | POLYETHYLENE INSULATED | | |
|  | FUSE (FUSE RATING) | TPX | TRIPLEX | | |
|  | LINE DISCONNECT/SWITCH N.C. : NORMALLY CLOSED N.O. : NORMALLY OPEN (NORMAL STATUS) (AMPS) | QPX | QUADPLEX | | |
|  | LB: LOAD BREAK | PRIMARY | | | |
| SERVICES | |  | SPLICE | | |
| | |  | 1-PH | | |
| | |  | 2-PH | | |
| | |  | 3-PH | | |
| | |  | FEEDER IDENTIFICATION (REFER TO CD130-15) | | |
| SERVICES | | SECONDARY | | | |
|  | CROSSING DRAWING |  | NEUTRAL | | |
| CABLES | |  | SPLICE | | |
| AL | ALUMINUM |  | 1-PH 2 COND SECONDARY | | |
| AS | ALUMINUM SOLID |  | 1-PH 3 COND SECONDARY | | |
| CU | COPPER |  | 3-PH 3 COND | | |
| PILC | PAPER INSULATED, LEAD COVERED |  | 3-PH 4 COND | | |
| DSTA | DOUBLE STEEL TAPE ARMOUR |  | SL FEED, 1 COND C/N | | |
| RINJ | RUBBER INSULATED, NEOPRENE JACKETED |  | SL FEED, 2 COND C/N | | |
| | |  | SL FEED TRIPLEX | | |
| APPROVED | REVISIONS | MANITOBA HYDRO DISTRIBUTION STANDARDS | | | |
| ORIGINAL DRAWING SEALED BY E.H. WIEBE 94-07-11 | | UNDERGROUND DISTRIBUTION SYMBOLS | | | |
| | 08-02 | | | 2 | UPDATED SYMBOLS |
| | 00-02 | | | 1 | REDRAWN, UPDATED SYMBOLS |

INSTALLATION INSTRUCTIONS

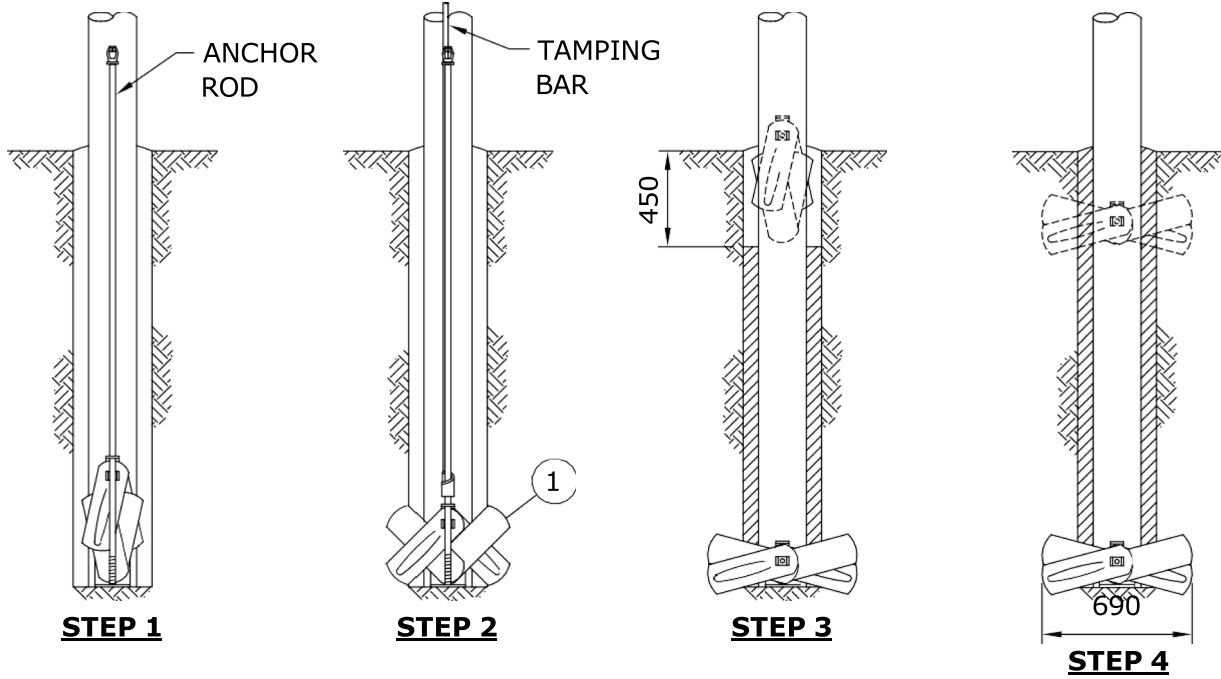

- STEP 1:** SCREW A 3/4" ANCHOR ROD (NOT INCLUDED WITH ANCHOR) INTO THE POLE KEY AND LOWER THE ASSEMBLY, IN THE CLOSED POSITION, INTO THE HOLE ON THE SIDE OPPOSITE THE STRAIN.
- STEP 2:** EXPAND THE KEY INTO SOLID EARTH WITH AN EXPANDING/TAMPING BAR.
- STEP 3:** WHEN THE KEY IS FULLY EXPANDED, REMOVE THE ROD AND REFILL HOLE, CAREFULLY COMPACTING SOIL BACKFILL IN STAGES, TO WITHIN 450mm OF THE GROUND LEVEL.
- STEP 4:** INSTALL A SECOND POLE KEY ON THE OPPOSITE SIDE OF THE POLE FROM THE ORIGINAL KEY, AND EXPAND INTO SOLID EARTH WITH A TAMPING BAR.

MATERIAL LIST

| ITEM No. | DESCRIPTION | MH CIIC CODE |
|----------|--|--------------|
| 1. | EXPANDING POLE KEY, 690mm (27 1/4") EXPANDED WIDTH, 276 sq. in. EXPANDING AREA | 02 20 01 |
| 2. | ROD, ANCHOR 3/4" | 71 31 34 |
| 3. | BAR, TAMPING | 06 10 60 |

NOTES:

- USE WITH SLACK SPANS (SEE CD42-30) AND LIGHTLY LOADED POLES WHERE A GUY & ANCHOR CANNOT BE USED (LOADS LESS THAN 3000N).
- DIMENSIONS SHOWN ARE MILLIMETRES.

| | | | | | | | |
|--|----------------------|---------------|--|--|--|------------------|-----------|
| APPROVED | REVISIONS | | | MANITOBA HYDRO DISTRIBUTION STANDARDS | | | |
| ORIGINAL DRAWING SEALED BY D.R. ORR 15-10-22 | 17-04 | 2 | REVISED NOTE 1 | COMPONENTS AND INSTALLATION OF EXPANDING POLE KEY ANCHORS | | | |
| | 16-12 | 1 | REVISED ANCHOR ROD, STEP 4, ITEM NO. 3, & NOTE 1 | | | | |
| | 15-06 | 0 | REPLACED CD40-48 | | | | |
| DRAWN C.A. | CHECKED G.D./D.O. | DATE 15-06 | CD 44-30 | | | SHT 0001 of 1 | REV 02 |

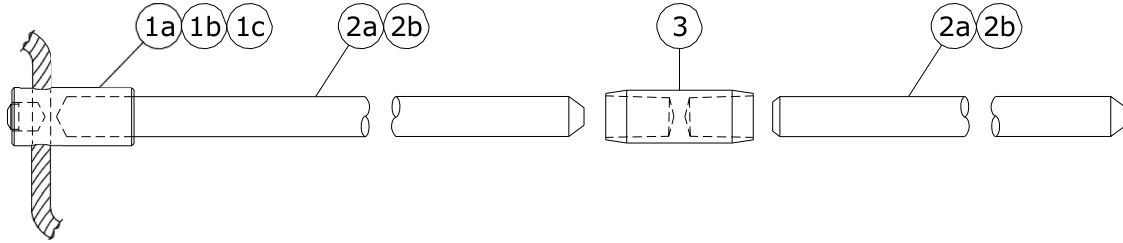

COPPERWELD - SECTIONAL

| ITEM No. | DESCRIPTION | MH CIIC |
|----------|--|----------|
| 1a | HAMMERLOCK FOR #2 & #4 CU | 04 60 24 |
| 1b | HAMMERLOCK FOR 1/0 & 2/0 CU | 06 62 13 |
| 1c | HAMMERLOCK FOR 3/0 & 4/0 CU | 06 62 14 |
| 2a | 10' CU-WELD ROD SECTIONAL (SEE NOTE 2) | 71 70 10 |
| 2b | 6' CU-WELD ROD SECTIONAL | 00 68 26 |
| 3 | COUPLING CU-WELD | 00 52 27 |

NOTES:

- FOR 3/4" GROUND RODS. IF A 5/8" GROUND ROD IS ENCOUNTERED, IT IS TO BE REPLACED WITH A 3/4" ROD.
- FIRST GROUND ROD SHALL BE A 10' ROD.
- FOR 06-62-14 HAMMERLOCK FOR 3/0 & 4/0 CU WHEN USED ON 3/0 CU, HAMMER DRIVE PIN FLUSH WITH TOP OF CONNECTOR AS PER MANUFACTURER'S INSTRUCTIONS.

SUPERCEDES ORIGINAL SEALED BY E. WIEBE ON 99-01-04

| | | | | | | | |
|--|-----------------|---------------|--|---------------------------------------|--|------------------|-----------|
| APPROVED | REVISIONS | | | MANITOBA HYDRO DISTRIBUTION STANDARDS | | | |
| ORIGINAL DRAWING SEALED BY D.R. ORR 21-06-01 | 21-04 | 4 | REVISED ITEM 1b & 1c, ADDED NOTE 3, REMOVED ITEM 4 & 5, RESEALED | GROUND ROD MATERIAL DETAIL | | | |
| | 13-01 | 3 | ADDED HAMMERLOCK CONNECTOR | | | | |
| | 08-07 | 2 | ADDED ELECTRONIC IGNITER & REVISED TABLE | | | | |
| DRAWN C.A. | CHECKED G.D. | DATE 21-01 | CD 50-7 | | | SHT 0001 of 1 | REV 04 |

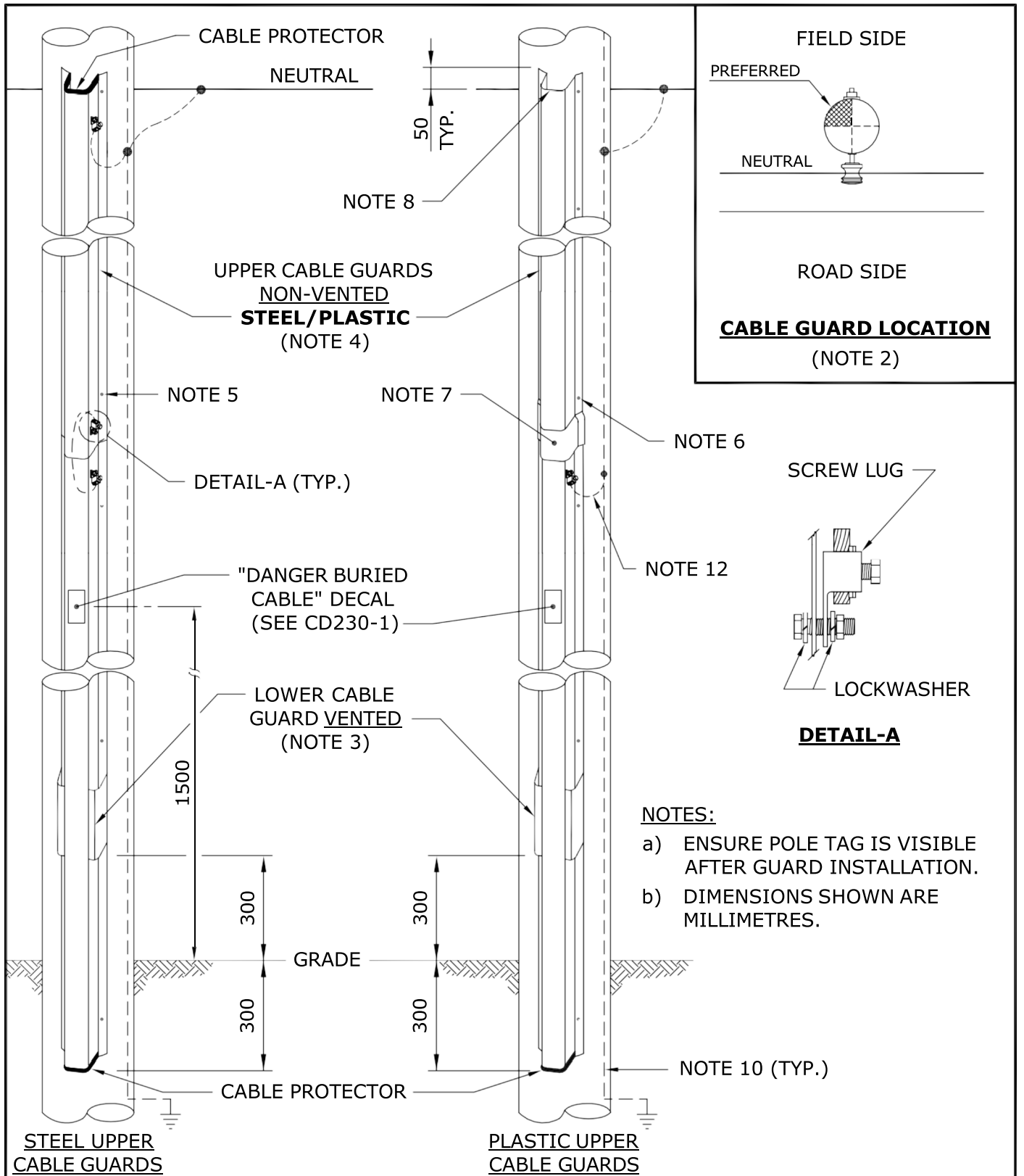

NOTES:

- a) ENSURE POLE TAG IS VISIBLE AFTER GUARD INSTALLATION.
- b) DIMENSIONS SHOWN ARE MILLIMETRES.

SUPERCEDES ORIGINAL SEALED BY E. WIEBE ON 94-07-03

| | | | | | |
|--|-----------------|---------------|-------------------------|---|-----|
| APPROVED | | REVISIONS | | MANITOBA HYDRO DISTRIBUTION STANDARDS | |
| ORIGINAL DRAWING SEALED BY J.J.D. RINGASH 15-10-29 | 23-06 | 5 | ADDED SHEET 3 | CABLE GUARD DETAILS ON DIP/RISER POLES | |
| | 16-04 | 4 | REVISED NOTE | | |
| | 15-10 | 3 | ADDED NOTE a), RESEALED | | |
| DRAWN C.A. | CHECKED K.S. | DATE 15-10 | | CD 200-63 | |
| | | | | SHT | REV |
| | | | | 0001 OF 3 | 05 |

NOTES:

1. FOR CABLE GUARD SELECTION GUIDE, REFER TO DRAWING CD200-66.
2. TO PROVIDE A SAFER CLIMBING SURFACE AND TO PREVENT VEHICULAR DAMAGE TO THE CABLE GUARD, THE PREFERRED ATTACHMENT OF THE CABLE GUARD TO THE POLE SHOULD BE IN THE QUADRANT AS SHOWN.
3. THE LOWER CABLE GUARD SHALL BE GALVANIZED STEEL AND VENTED.
4. UPPER CABLE GUARD SHALL BE PLASTIC FOR THE 50mm & 90mm GUARDS AND GALVANIZED STEEL FOR THE 130mm GUARD.
5. ATTACH GALVANIZED STEEL CABLE GUARD TO POLE WITH 3/8" LAG SCREWS (72-60-03).
6. ATTACH THE PLASTIC CABLE GUARD TO THE POLE WITH #16 x 2" WOOD SCREWS (72-95-10), C/W FLAT WASHERS (86-10-04).
7. POSITION THE LAP-JOINT OF THE PLASTIC CABLE GUARD DOWN & OVER LAPPED A MINIMUM OF 25mm ONTO THE VENTED CABLE GUARD.
8. ENSURE THAT THE INNER EDGE IS BEVELLED.
9. CABLE GUARD TO EXTEND 50mm ABOVE THE NEUTRAL CONDUCTOR.
10. GROUNDING AND BONDING CONDUCTORS SHALL BE #4 BARE COPPER.
11. FOR GROUNDING CONNECTIONS, REFER TO DRAWING CD200-60.
12. BOND VENTED CABLE GUARD AT THIS POINT.

SUPERCEDES ORIGINAL SEALED BY E. WIEBE ON 99-11-03

| | | | | | |
|--|-----------------|---------------|------------------------------|---|------------------|
| APPROVED | | REVISIONS | | MANITOBA HYDRO DISTRIBUTION STANDARDS | |
| ORIGINAL DRAWING SEALED BY J.J.D. RINGASH 15-10-29 | 23-06 | 3 | ADDED SHEET 3 | CABLE GUARD DETAILS ON DIP/RISER POLES | |
| | 16-04 | 2 | ADDED FLAT WASHERS TO NOTE 6 | | |
| | 15-10 | 1 | RESEALED | | |
| DRAWN C.A. | CHECKED K.S. | DATE 15-10 | CD 200-63 | | SHT 0002 of 3 |
| | | | | | REV 03 |

| SECONDARY CABLE | TYPICAL USAGE |
|---------------------------|---|
| #4 AL. CONCENTRIC NEUTRAL | STREET LIGHT CIRCUITS |
| 1/0 AL. TRIPLEX | SECONDARY RESIDENTIAL SERVICES AND HEAVILY LOADED STREET LIGHT CIRCUITS WHERE VOLTAGE DROP MAY BE A PROBLEM |
| 4/0 AL. TRIPLEX | SECONDARY RESIDENTIAL SERVICES |
| 350 TRIPLEX | SECONDARY RESIDENTIAL SERVICES |
| 4/0 AL. TRIPLEX | THREE PHASE SECONDARY SERVICES ADD #2 Cu BARE NEUTRAL UP TO 200 AMP |
| 350 AL. QUADRAPLEX | THREE PHASE SECONDARY SERVICES 400 AMP OR 200A OVER 75m |
| 750 AL. OR 1000 CU. | THREE PHASE SECONDARY SERVICES OVER 400 AMPS |

NOTE:

SEE CD225-4 FOR SIZING AND SPACING OF SINGLE AND THREE PHASE CONDUCTORS.

SUPERCEDES ORIGINAL SEALED BY E. WIEBE ON 88-03-29

| | | | | | |
|--|-----------------|---------------|--|---------------------------------------|------------------|
| APPROVED | | REVISIONS | | MANITOBA HYDRO DISTRIBUTION STANDARDS | |
| ORIGINAL DRAWING SEALED BY J.J.D. RINGASH 17-01-25 | 17-01 | 11 | ADDED 4/0 AL TRIPLEX TO TABLE, RESEALED | UNDERGROUND SECONDARY CABLE | |
| | 06-03 | 10 | ADDED NOTE AND 350 TRIPLEX | | |
| | 99-04 | 9 | 4/0 AL. TRIPLEX, NOTE CHANGED | | |
| DRAWN C.A. | CHECKED K.S. | DATE 17-01 | CD 210-12 | | SHT 0001 of 2 |
| | | | | | REV 11 |

BASIC CONSTRUCTION OF UNDERGROUND SECONDARY CABLES

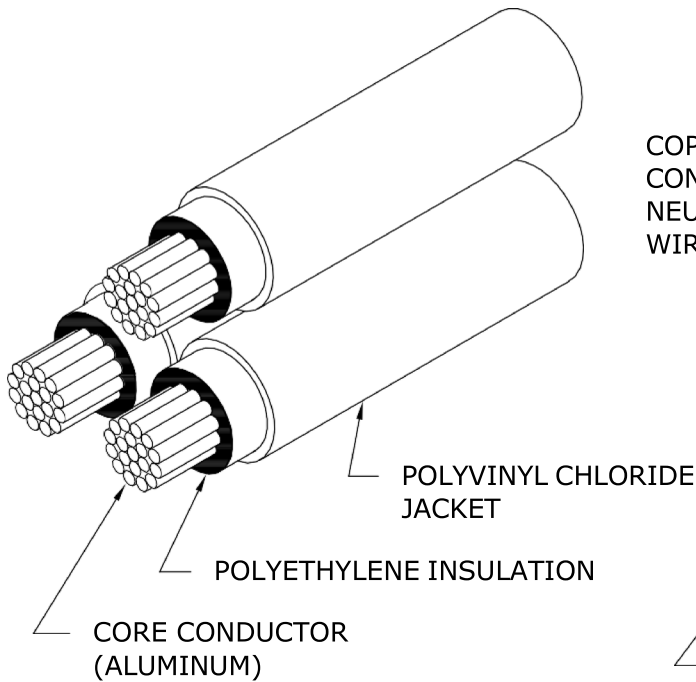

1/0 & 4/0 AND 350 TRIPLEX

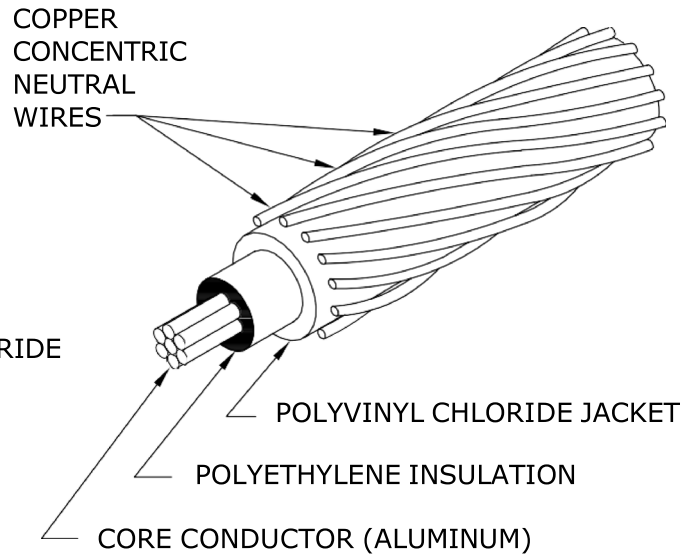

4 CONCENTRIC NEUTRAL CABLE

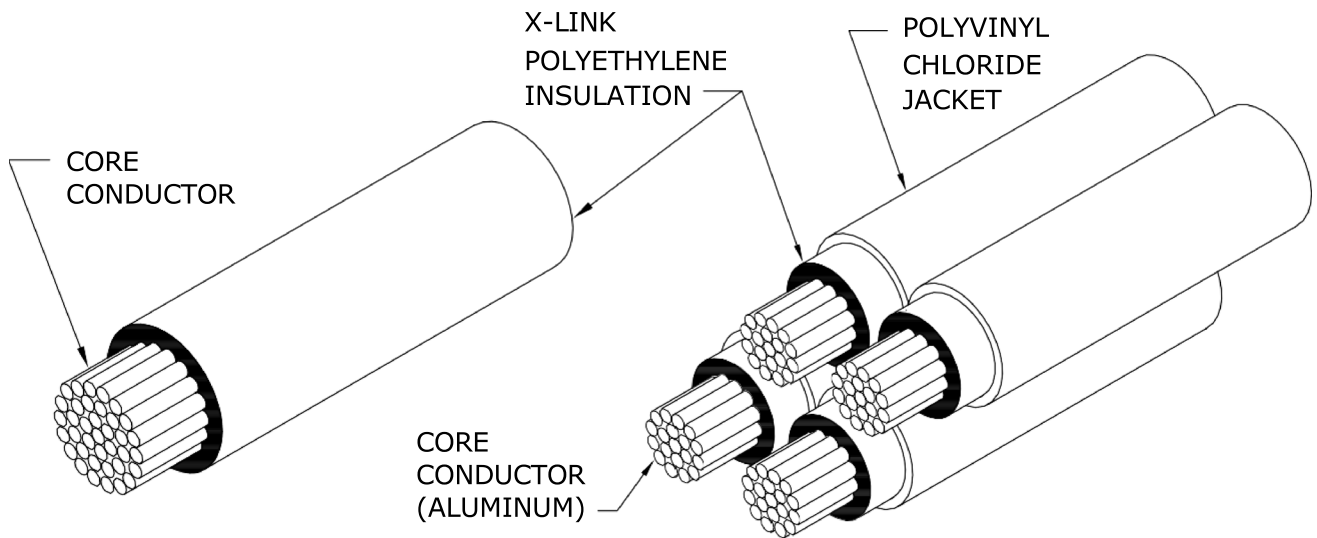

750 kcmil (AL) & 1000 kcmil (CU) RWU

350 kcmil QUADRAPLEX

| | | | | | | |
|--|-----------------|---------------|--|---------------------------------------|--|------------------|
| APPROVED | REVISIONS | | | MANITOBA HYDRO DISTRIBUTION STANDARDS | | |
| ORIGINAL DRAWING SEALED BY E.H. WIEBE 94-07-03 | 06-03 | 2 | REPLACED 4/0 TRIPLEX WITH 4/0 & 350 TRIPLEX | UNDERGROUND SECONDARY CABLE | | |
| | 95-01 | 1 | C/N WIRES NO LONGER TINNED | | | |
| | 93-07 | 0 | 500 MCM DELETED 350 750 kcmil ADDED FORMERLY CD210-3 | | | |
| DRAWN W.B./CAD | CHECKED B.H. | DATE 93-07 | | CD 210-12 | | SHT 0002 of 2 |
| | | | | | | REV 02 |

UNDERGROUND SECONDARY CABLE

| | | | | | | | |
|--|---------------------------|-----------|-----------|---------------------|-----------|------------|------------|
| VOLTAGE RATING | 600V | 600V | 600V | 600V | 1000V | 1000V | 1000V |
| CORE CONDUCTOR SIZE | #4 | 1/0 | 4/0 | 350 kcmil | 750 kcmil | 1000 kcmil | 1000 kcmil |
| CORE CONDUCTOR MATERIAL | ALUM. | ALUM. | ALUM. | ALUM. | ALUM. | ALUM. | COPPER |
| TYPE OF CABLE | C/N | TRIPLEX | TRIPLEX | TRIPLEX OR QUADPLEX | 1-COND. | 1-COND. | 1-COND. |
| NEUTRAL SIZE AND TYPE | #6 CU. Concentric Neutral | 1/0 ALUM. | 4/0 ALUM. | 350 kcmil ALUM. | NONE | NONE | NONE |
| MIN. BENDING RADIUS (mm) | 125 | 115 | 150 | 180 | 250 | 300 | 300 |
| DC RESISTANCE @ 20°C (OHMS/km) | 1.360 | 0.538 | 0.269 | 0.163 | 0.076 | 0.057 | 0.035 |
| ** DIRECT BURIED AMPACITY (@ 20°C ambient) | 125 | 215 | 300 | 420 | * 725 | * 840 | * 1080 |
| VENTED CABLE GUARD AMPACITY (@ 20°C ambient) | 100 | 175 | 250 | 330 | 575 | 680 | 855 |
| *** BURIED DUCT AMPACITY (@ 20°C ambient) | 70 | 130 | 195 | 265 | 425 | 495 | 630 |
| CONDUCTOR DIAMETER (mm) | 5.4 | 8.9 | 12.7 | 15.8 | 25 | 26.9 | 26.9 |
| NOMINAL DIA. OVER INSUL. (mm) | 8.6 | 12.5 | 16.5 | 21.6 | 31.4 | 33.5 | 33.5 |
| NOMINAL DIA. OVER JACKET (mm) | 12.74 | 14.7 | 17.8 | 22.8 | N/A | N/A | N/A |
| LINEAL MASS (kg/km) | N/A | 760 | 1320 | 2200/2900 | 1330 | 1369 | 4983 |
| COLD SHRINK END CAPS (MH CIIC) | N/A | 15 31 40 | 15 31 40 | 15 31 60 | 15 31 75 | 15 31 75 | 15 31 75 |
| HEAT SHRINK END CAPS (MH CIIC) | 03 67 31 | 03 67 31 | 03 67 31 | 03 67 30 | 01 79 82 | 03 48 63 | 03 48 63 |

* PROVIDED MULTIPLE CONDUCTORS PER PHASE ARE SPACED AS SHOWN IN DRAWING CD225-4.

** CABLES DIRECTLY BURIED OUT OF PADMOUNT TRANSFORMERS OR PEDESTALS.

*** CABLES IN NON-VENTED CABLE GUARDS OR IN CONDUITS LONGER THAN 2 METRES.

SUPERCEDES ORIGINAL SEALED BY E. WIEBE ON 94-07-03

| | | | | | | | | |
|--|-----------------|--|--|------------------|--|--|------------------|-----------|
| APPROVED ORIGINAL DRAWING SEALED BY J.J.D. RINGASH 16-03-30 | REVISIONS | | MANITOBA HYDRO DISTRIBUTION STANDARDS | | | | | |
| | 17-01 | 5 | REVISED TABLE | | STANDARD UNDERGROUND SECONDARY CABLE DATA | | | |
| | 16-03 | 4 | ADDED 1000 kcmil ALUM. COND., REVISED DATE, RESEALED | | | | | |
| 08-12 | 3 | ADDED COLD & HEAT SHRINK CAPS AND LINEAL MASS TO TABLE | | | | | | |
| DRAWN C.A. | CHECKED J.R. | DATE 16-03 | | CD 210-15 | | | SHT 0001 of 1 | REV 05 |

1-04431-DA-58041-0009

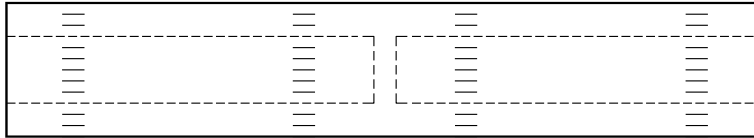

- FOR SPLICING SECONDARY ALUMINUM/COPPER CONDUCTORS.
- NOT SUITABLE FOR USE ON PRIMARY CONDUCTORS.
- COMPLETE WITH BARRIER TO PREVENT MOISTURE MIGRATION.
- FILLED WITH SYNTHETIC INHIBITOR.
- STAMPED WITH CONDUCTOR AND DIE SIZE.
- **COMPRESSION TOOL DIE MUST MATCH DIE NUMBER STAMPED ON CONNECTOR.**
- WIRE BRUSH ALL CONDUCTORS PRIOR TO INSTALLING CONNECTOR.

*** UNDERGROUND SECONDARY CABLE COMPRESSION CONNECTORS**

| CONDUCTOR SIZE | | STORES CODE | TOOL (DIES) | |
|----------------|-----|-------------|--------------------|-----------------------|
| FROM | TO | | PREFERRED | ALTERNATE |
| #4 | #4 | 74 27 64 | Y35 (UCSA 22) | ** MD6 (WCSA 22, BG) |
| 1/0 | #2 | 74 27 30 | | |
| 1/0 | 1/0 | 74 27 65 | | |
| 4/0 | 1/0 | 74 27 67 | Y35 (UCSA 24) | ** MD6 (WCSA 24, 249) |
| 4/0 | 4/0 | 74 27 68 | | |
| 350 | 4/0 | 74 27 78 | Y35 (UCSA 28) | --- |
| 350 | 350 | 74 27 72 | | |
| 750 | 500 | 74 27 27 | Y46/ADPT (UCSA 30) | --- |

* FOR CONNECTING INSULATED ALUMINUM TO BARE COPPER, REFER TO DRAWING CD215-13.

** ROTATE MD6 TOOL 180° AFTER EVERY CRIMP.

| | | | | | | |
|--|-----------------|---------------|------------------|---|------------------|-------------------------|
| APPROVED | | REVISIONS | | MANITOBA HYDRO DISTRIBUTION STANDARDS | | |
| ORIGINAL DRAWING SEALED BY E.H. WIEBE 94-07-03 | | | | UNDERGROUND SECONDARY CABLE COMPRESSION CONNECTORS | | |
| | | 95-09 | 2 | | | 350-4/0 CONNECTOR ADDED |
| | | 95-01 | 1 | | | NOTE ON MD6 TOOL ADDED |
| DRAWN W.B./CAD | CHECKED G.W. | DATE 93-07 | CD 210-21 | | SHT 0001 of 1 | |
| | | | | | REV 02 | |

- COMPRESSION TOOL DIE MUST MATCH DIE NUMBER STAMPED ON CONNECTOR.
- WIRE BRUSH CONDUCTORS PRIOR TO INSTALLING COMPRESSION CONNECTORS.

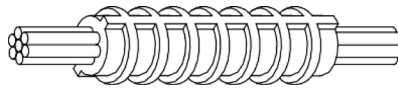

| UNDERGROUND NEUTRAL COMPRESSION CONNECTORS | | | |
|---|-----|-------------|-------------|
| CONDUCTOR SIZE | | STORES CODE | TOOL (DIES) |
| FROM | TO | | |
| #4 | #4 | 74 32 04 | MD6 (162) |
| #2 | #2 | 74 32 02 | MD6 (163) |
| 2/0 | 2/0 | 74 31 26 | MD6 (166) |
| 4/0 | 4/0 | 74 31 28 | Y35 (168) |
| 350 | 350 | 74 32 31 | Y35 (267) |

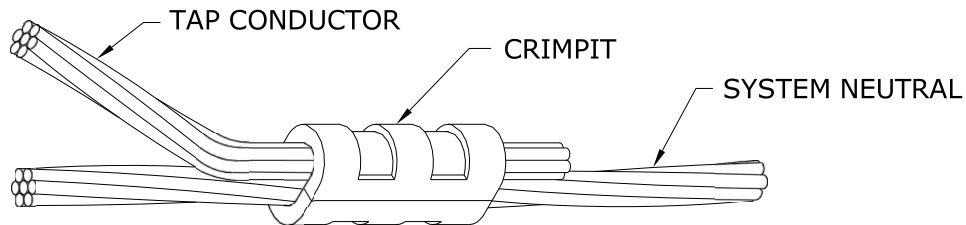

| UNDERGROUND NEUTRAL "C" TYPE (CRIMPIT) COMPRESSION CONNECTORS | | | |
|--|-----------|-------------|-------------|
| * (FOR USE ON COPPER CONDUCTORS ONLY) | | | |
| CONDUCTOR SIZE | | STORES CODE | TOOL (DIES) |
| RUN | TAP | | |
| #6 - #4 | #6 | 74 41 10 | MD6 (BG) |
| #4 | #4 | 74 40 90 | MD6 (BG) |
| #2 | #4 | 74 40 80 | MD6 (WC) |
| #2 | #2 | 74 40 70 | MD6 (WC) |
| 1/0 - 2/0 | 1/0 - 2/0 | 74 41 12 | Y35 (UO) |
| 3/0 - 250 | #6 - 2/0 | 74 41 15 | Y35 (U997) |
| 3/0 - 250 | 3/0 - 250 | 74 41 16 | Y35 (U997) |
| 300 - 500 | #6 - 2/0 | 54 23 60 | Y46 (P1011) |
| 300 - 500 | 3/0 - 250 | 18 30 74 | Y46 (P1011) |

* FOR CONNECTING BARE COPPER TO INSULATED ALUMINUM, REFER TO DRAWING CD215-13.

| | | | | |
|--|-------------------|---------------------------------------|---------------------------------------|---|
| APPROVED ORIGINAL DRAWING SEALED BY E.H. WIEBE 94-07-03 | REVISIONS | | MANITOBA HYDRO DISTRIBUTION STANDARDS | |
| | 10-12 | 2 | ADDED CONNECTOR | UNDERGROUND NEUTRAL COMPRESSION CONNECTORS |
| | 95-01 | 1 | NOTES REARRANGED | |
| 93-07 | 0 | CONNECTORS ADDED, FORMERLY CD210-8 | | |
| DRAWN W.B./CAD | CHECKED K.C.H. | DATE 93-07 | CD 210-24 | |
| | | | SHT 0001 of 1 | REV 02 |

THERE ARE THREE METHODS FOR SPLICING 600 VOLT UNDERGROUND SECONDARY CABLES:

- 1) HEAT SHRINK INSULATING TUBING SPLICE
- 2) PRE-STRETCHED INSULATING TUBING SPLICE
- 3) TAPED SPLICE

750 kcmil AND 1000 kcmil CABLES, USED IN CONJUNCTION WITH 3-PHASE COMMERCIAL SERVICES, SHALL NOT BE SPLICED, EXCEPT FOR EMERGENCY REPAIRS.

GENERAL INSTRUCTIONS:

1. a) FOR 1/0 AND 4/0 TRIPLEX CABLES:

- REMOVE ANY DAMAGED OR CONTAMINATED PORTIONS OF CABLE.
- TRAIN CABLES INTO FINAL POSITION (DO NOT SNAKE IN TRENCH).
- CUT CABLES SQUARE AND BUTT ENDS.
- STAGGER SPLICES.
- PROCEED TO STEP 2.

b) FOR #4 CONCENTRIC NEUTRAL CABLE:

- REMOVE ANY DAMAGED OR CONTAMINATED PORTIONS OF CABLE.
- TRAIN CABLES INTO FINAL POSITION WITH ENDS OVERLAPPING C/L BY 150mm.
- TIGHTLY TWIST CONCENTRIC NEUTRAL WIRES INTO A BUNDLED CONDUCTOR FOR APPROXIMATELY 250mm AND TEMPORARILY FOLD BACK.
- CUT OFF APPROXIMATELY 100mm OF CABLE FROM EACH END.
- PROCEED TO STEP 2.

2. SELECT APPROPRIATE SLEEVE AND DIE ACCORDING TO DRAWING CD210-21.

3. SELECT SPLICING METHOD (FOR CORRECT MANUFACTURED SPLICES, REFER TO TABLE ON SHEET 2 of 3).

NOTE:

FOR SPLICING BARE COPPER NEUTRAL WIRE TO INSULATED ALUMINUM CABLE, REFER TO DRAWING CD215-13.

4. REMOVE JACKET AND INSULATION FROM CABLES AS PER FIGURE 1 OR FOLLOW MANUFACTURERS INSTRUCTIONS; BE CAREFUL NOT TO NICK INSULATION OR CONDUCTOR.

5. CLEAN CONDUCTOR WITH WIRE BRUSH. INSTALL CONNECTOR.

NOTE:

EXCEPT FOR TAPED SPLICE, SLIDE TUBING OVER ONE CONDUCTOR BEFORE INSTALLING CONNECTOR.

SUPERCEDES ORIGINAL SEALED BY E. WIEBE ON 94-07-03

| | | | | | | | | | |
|--|-----------------|---------------|---|---|--|-----|-----|-----------|----|
| APPROVED | | REVISIONS | | MANITOBA HYDRO DISTRIBUTION STANDARDS | | | | | |
| ORIGINAL DRAWING SEALED BY J.J.D. RINGASH 17-10-11 | 17-10 | 3 | REMOVED RAYCHEM RAYVOLVE SPLICING, RESEALED | SPLICES FOR UNDERGROUND SECONDARY CABLES | | | | | |
| | 96-05 | 2 | NOTES REVISED, SHEET 3 ADDED | | | | | | |
| | 95-01 | 1 | NOTES 3, 7 & TABLE ADDED | | | | | | |
| DRAWN C.A. | CHECKED K.S. | DATE 17-10 | CD 215-12 | | <table border="1"> <tr> <td>SHT</td> <td>REV</td> </tr> <tr> <td>0001 of 3</td> <td>03</td> </tr> </table> | SHT | REV | 0001 of 3 | 03 |
| SHT | REV | | | | | | | | |
| 0001 of 3 | 03 | | | | | | | | |

6. CLEAN JACKET (50mm), INSULATION, AND CONNECTOR WITH AN APPROVED CLEANING SOLVENT (S.C.# 43 11 95).
7. COMPLETE SELECTED SPLICE (AS CHOSEN IN STEP 3).
NOTE:
TO COMPLETE #4 CONCENTRIC NEUTRAL SPLICE, PROCEED TO STEP 8.
8. FOR #4 CONCENTRIC NEUTRAL CABLE: (CONT'D)
 - a) APPLY 1 LAYER OF 1/4 STRETCHED 50mm WIDE RUBBER MASTIC TAPE (S.C.#78 55 28) OVER CENTRE OF COMPLETED SPLICE.
 - b) TRAIN TWISTED CONCENTRIC NEUTRAL WIRE (STEP 1b) INTO FINAL POSITION ALLOWING ADEQUATE CLEARANCE FOR MD6 PRESS.
 - c) PLACE "C" TYPE COMPRESSION CONNECTOR OVER TWISTED WIRES AND CRIMP. REFER TO DRAWING CD210-24.
 - d) TRIM OFF PROTRUDING WIRES AND COMPRESS WITH PLIERS ELIMINATING ANY SHARP ENDS.
 - e) APPLY A 100mm STRIP OF 50mm WIDE RUBBER MASTIC TAPE OVER CONNECTOR AND PROTRUDING WIRES.

NOTE:

SHINY SIDE AGAINST CONNECTOR AND THE 100mm LENGTH PARALLEL TO CONNECTOR AND WIRE.

- f) FORM TAPED CONCENTRIC NEUTRAL CONNECTION AND WIRES AROUND SPLICE AND CABLE.
- g) APPLY 2 LAYERS 3/4 STRETCHED COLD WEATHER VINYL TAPE (S.C.#78 55 98) OVER TAPED CONCENTRIC NEUTRAL CONNECTION AND SPLICE, APPROXIMATELY 50mm WIDE.

| MANUFACTURED SPLICES FOR SECONDARY CABLES | | |
|---|----------------|-------------|
| CONDUCTOR SIZE | TYPE OF SPLICE | STORES CODE |
| #4 TO 1/0 | PRESTRETCHED | 85 13 10 |
| 4/0 TO 350 | PRESTRETCHED | 85 13 40 |
| | HEAT SHRINK | 85 13 50 |

SUPERCEDES ORIGINAL SEALED BY E. WIEBE ON 94-07-03

| | | | | | | | | | |
|--|-----------------|---------------|---------------------------------------|---|--|-----|-----|-----------|----|
| APPROVED | | REVISIONS | | MANITOBA HYDRO DISTRIBUTION STANDARDS | | | | | |
| ORIGINAL DRAWING SEALED BY J.J.D. RINGASH 17-10-11 | 17-08 | 4 | REVISED TABLE, RESEALED | SPLICES FOR UNDERGROUND SECONDARY CABLES | | | | | |
| | 15-02 | 3 | REMOVED RAYVOLVE SPLICE FROM TABLE | | | | | | |
| | 08-03 | 2 | REVISED TABLE AND NOTE 6 | | | | | | |
| DRAWN C.A. | CHECKED K.S. | DATE 17-08 | CD 215-12 | | <table border="1"> <tr> <td>SHT</td> <td>REV</td> </tr> <tr> <td>0002 of 3</td> <td>04</td> </tr> </table> | SHT | REV | 0002 of 3 | 04 |
| SHT | REV | | | | | | | | |
| 0002 of 3 | 04 | | | | | | | | |

FOR TAPED SPLICE

TAPES SHALL ONLY BE APPLIED DIRECTLY FROM ROLL ONTO SPLICE, HALF LAPPED AND STRETCHED TO 3/4 OF THEIR ORIGINAL WIDTH.

1. APPLY 3 LAYERS OF SELF-AMALGAMATING ETHYLENE PROPYLENE RUBBER (E.P.R.) TAPE (S.C.#78 55 23) AS PER FIGURE 2.
2. APPLY 2 LAYERS OF COLD WEATHER VINYL TAPE (S.C.#78 55 98) AS PER FIGURE 2.

OR

APPLY 3 LAYERS OF SELF-AMALGAMATING HIGH TEMPERATURE SILICONE TAPE (S.C.#03 74 67). VINYL TAPE IS NOT REQUIRED.

NOTE:
DIMENSIONS SHOWN
ARE MILLIMETRES.

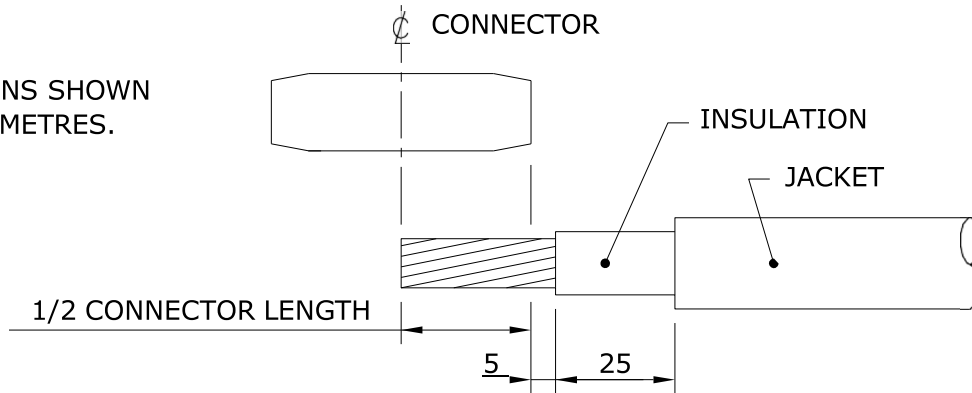

FIGURE 1

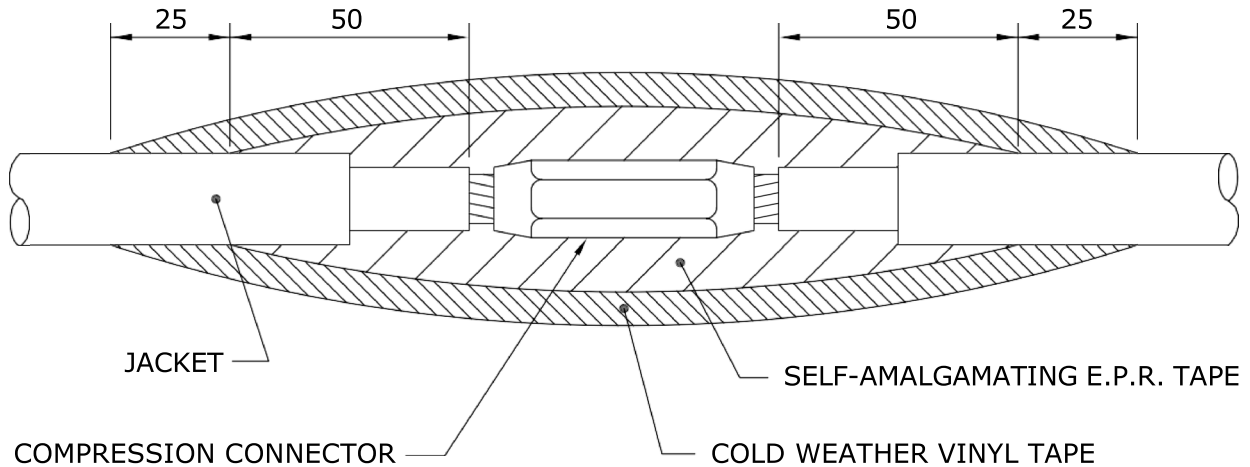

FIGURE 2

SUPERCEDES ORIGINAL SEALED BY E. WIEBE ON 97-01-08

| | | | | |
|--|-----------|-------|---|----|
| APPROVED | REVISIONS | | MANITOBA HYDRO DISTRIBUTION STANDARDS | |
| ORIGINAL DRAWING SEALED BY J.J.D. RINGASH 17-10-11 | 17-10 | 2 | RESEALED | |
| | 10-12 | 1 | REVISED COMPRESSION CONNECTOR AND NOTE 2 | |
| | DATE | | SPLICES FOR UNDERGROUND SECONDARY CABLES | |
| DRAWN | CHECKED | DATE | | |
| C.A. | K.S. | 17-10 | CD 215-12 | |
| | | | | |
| | | | 0003 of 3 | 02 |

CABLE PREPARATION:

- ① REMOVE PVC (POLYVINYL CHLORIDE) JACKET TO DIMENSION "A" PLUS 25mm.
- ② REMOVE POLYETHYLENE INSULATION TO DIMENSION "A" PLUS 5mm. USE ABRASIVE TAPE (SC. 78 50 04) ON ALL CONNECTON SURFACES.
- ③ INSTALL ROD CONNECTOR AS PER TABLE BELOW AND FIGURE 1.

| CONDUCTOR SIZE | * ROD CONNECTOR STORES CODE No. | PRESS | DIE |
|----------------|---------------------------------|---------|--------|
| 1/0 ALUMINUM | 74 27 62 | Y35/MD6 | CSA 22 |
| 4/0 ALUMINUM | 74 27 69 | Y35/MD6 | CSA 24 |

* ROD IS FACTORY CRIMPED INTO CONNECTOR

- ④ CONNECT BARE COPPER STRANDED WIRE TO ROD CONNECTOR AS PER TABLE BELOW. USE ABRASIVE TAPE ON ALL CONNECTON SURFACES.

| CONDUCTOR SIZE | CONNECTOR STORES CODE No. | PRESS | DIE |
|----------------------------------|---------------------------|---------|-----|
| COPPER ROD TO #4 COPPER STRANDED | 74 40 90 | Y35/MD6 | WBG |
| COPPER ROD TO #2 COPPER STRANDED | 74 40 70 | MD6 | WC |

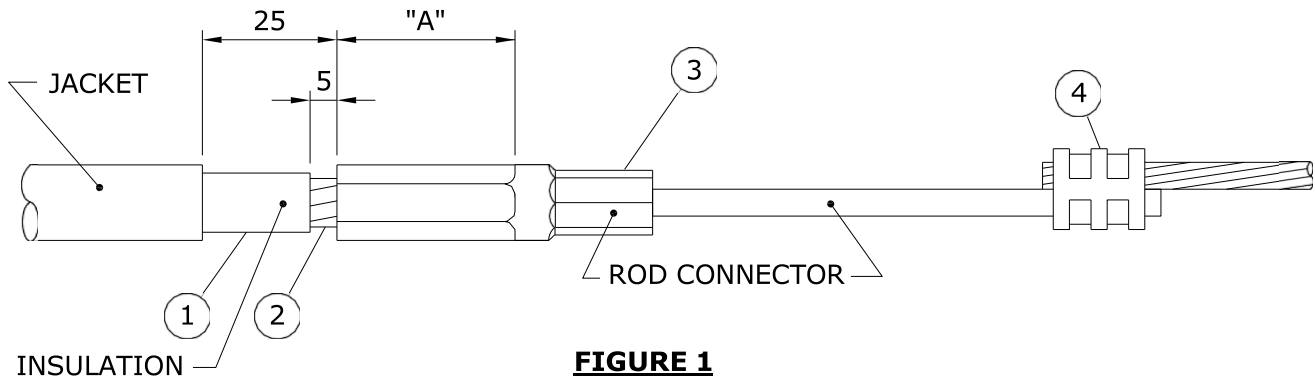

FIGURE 1

NOTE: DIMENSIONS SHOWN ARE MILLIMETRES.

| | | | | |
|--|------------------------|---------------|---|-----------|
| APPROVED ORIGINAL DRAWING SEALED BY E.H. WIEBE 94-07-03 | REVISIONS | | MANITOBA HYDRO DISTRIBUTION STANDARDS | |
| | 08-11 | 2 | SPLICING SECONDARY NEUTRAL (BARE COPPER TO INSULATED ALUMINUM) | |
| | 94-10 | 1 | | |
| DRAWN W.B./CAD | CHECKED B.H./K.C.H. | DATE 94-06 | CD 215-13 | |
| | | | SHT 0001 of 2 | REV 02 |

TAPING:

- ⑤ ABRASE ROD PORTION OF ROD CONNECTOR WITH ABRASIVE TAPE AS SHOWN IN FIGURE 2.
- ⑥ CLEAN JACKET, INSULATION & ROD CONNECTOR WITH AN APPROVED CLEANING SOLVENT (S.C.# 43 11 95).
- ⑦ CUT ONE PIECE OF RUBBER MASTIC TAPE (S.C. 78 55 28) INTO EITHER A 50mm WIDE x 75mm LONG STRIP FOR 1/0 CONNECTOR OR A 50mm WIDE x 125mm LONG STRIP FOR 4/0 CONNECTOR.
- ⑧ APPLY THE PRECUT STRIP OF RUBBER MASTIC TAPE 1/4 STRETCHED, SHINING SIDE DOWN ONTO THE ROD AS SHOWN IN FIGURE 2.
- ⑨ APPLY 2 LAYERS OF HALF LAPPED 3/4 STRETCHED SELF AMALGAMATING ETHYLENE PROPYLENE RUBBER TAPE (S.C.# 78 55 23) AS SHOWN IN FIGURE 2.
- ⑩ APPLY 2 LAYERS OF HALF LAPPED 3/4 STRETCHED COLD WEATHER VINYL TAPE (S.C.# 78 55 98) AS SHOWN IN FIGURE 2.

NOTE:

WHEN INSTALLING A MANUFACTURED SPLICE INCLUDE STEPS 5 THRU 8 WITH THE MANUFACTURERS INSTRUCTIONS. THIS WILL PROVIDE THE PROPER INSULATION AND MOISTURE SEAL.

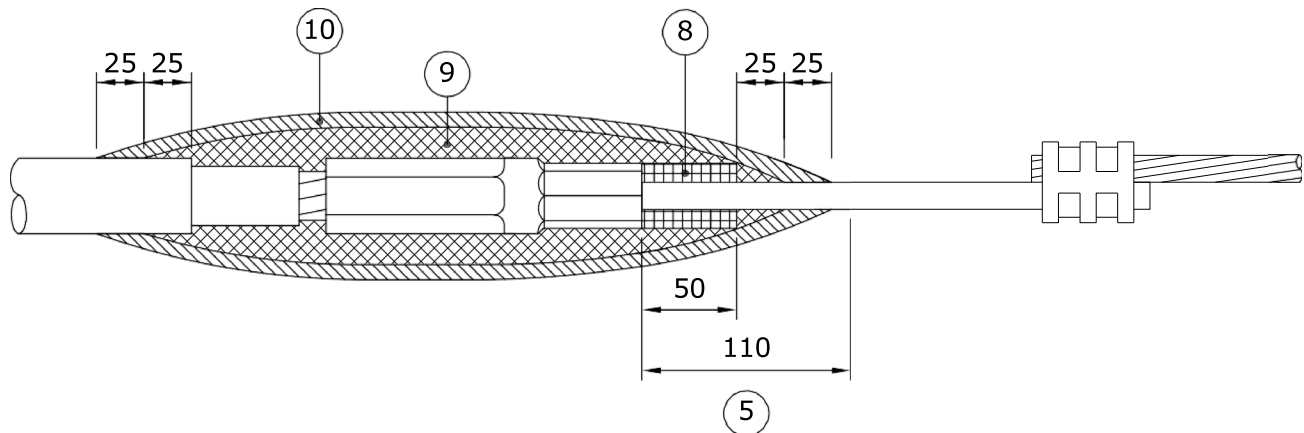
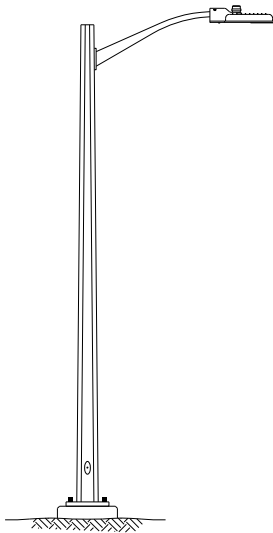

FIGURE 2

NOTE: DIMENSIONS SHOWN ARE MILLIMETRES.

| | | | | | |
|--|-------------------|---------------|---|-----------|--|
| APPROVED | REVISIONS | | MANITOBA HYDRO DISTRIBUTION STANDARDS | | |
| ORIGINAL DRAWING SEALED BY E.H. WIEBE 94-07-03 | | | SPLICING SECONDARY NEUTRAL (BARE COPPER TO INSULATED ALUMINUM) | | |
| | 08-11 | 2 | | | REVISED NOTE 6 & COMPRESSION CONNECTOR |
| | 94-10 | 1 | | | TAPING PROCEDURE REVISED |
| DRAWN W.B./CAD | CHECKED K.C.H. | DATE 94-06 | CD 215-13 | | |
| | | | SHT 0002 of 2 | REV 02 | |



STRAIGHT SHAFT

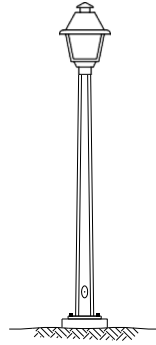

**POST-TOP BM
COLONIAL**
(BASE MOUNTED)

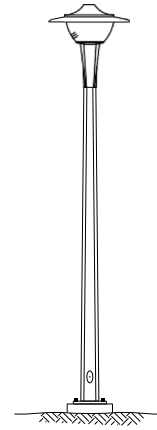

**POST-TOP BM
CONTEMPORARY**
(BASE MOUNTED)

| POLE TYPE | COLOUR | MOUNTING HEIGHT m (ft) | ARM REACH m ** | BOLT SQUARE mm | BOLT CIRCLE mm | STORES CODE NO. | CABLE LENGTH m *** |
|-----------------------------|----------------------|---------------------------|-------------------|---------------------|---------------------|-----------------|-----------------------|
| STRAIGHT SHAFT | GALVANIZED | 7.7 (25) | 1.8 | 179 - 206 (SLOTTED) | 254 - 292 (SLOTTED) | 05-05-78 | 11 |
| STRAIGHT SHAFT * | GALVANIZED | 9.1 (30) | 3.0 | 197 - 206 (SLOTTED) | 279 - 292 (SLOTTED) | 05-05-79 | 14 |
| STRAIGHT SHAFT | GALVANIZED | 10.7 (35) | 3.0 | 206 | 292 | 05-05-80 | 15 |
| STRAIGHT SHAFT **** | GALVANIZED | 10.7 (35) | 3.0 | 206 | 292 | 06-02-01 | 15 |
| STRAIGHT SHAFT | GALVANIZED | 13.7 (45) | 3.0 | 243 | 343 | 05-05-81 | 18 |
| STRAIGHT SHAFT | GALVANIZED | 16.8 (55) | 1.8 | N/A | 483 | 75-46-55 | 20 |
| STRAIGHT SHAFT | GALVANIZED | 19.8 (65) | 1.8 | N/A | 483 | 75-46-65 | 23 |
| POST-TOP BM COLONIAL | BLACK POWDER COAT | 4.7 (15) | N/A | 179 - 206 (SLOTTED) | 254 - 292 (SLOTTED) | 75-41-15 | 6 |
| POST-TOP BM CONTEMPORARY | GALVANIZED | 6.1 (20) | N/A | 179 - 206 (SLOTTED) | 254 - 292 (SLOTTED) | 75-41-22 | 7 |

NOTES:

- * FOR REPLACEMENT PURPOSES; NOT TO BE USED FOR NEW INSTALLATIONS.
- ** DO NOT MOUNT ALUMINUM ARM ON 16.8m AND 19.8m. DO NOT USE ALUMINUM ARMS WITH 1000W HPS LUMINAIRES. STRAIGHT SHAFT POLES CAN ACCOMMODATE A MAXIMUM OF 2 ARMS.
- *** LENGTH OF 2 CONDUCTORS #12 CABLE REQUIRED PER POLE.
- **** POLE INCLUDES A 1 1/8" DIAMETER HOLE AT 5m (STREET SIDE) FOR DECORATIVE LIGHTING RECEPTACLE. WIRE AS PER CD315-24.

SUPERCEDES ORIGINAL SEALED BY E. WIEBE ON 89-04-28

| | | | | | | | | |
|--|---------|-----------|---|--|--|--|-----|-----|
| APPROVED | | REVISIONS | | MANITOBA HYDRO DISTRIBUTION STANDARDS | | | | |
| ORIGINAL DRAWING SEALED BY J.J.D. RINGASH 21-07-30 | 21-07 | 4 | ADDED STRAIGHT SHAFT, REMOVED DAVIT BM & SQUARE BM, REVISED NOTES, RESEALED | STANDARD STEEL STREET LIGHT POLES | | | | |
| | 13-01 | 3 | ADDED CONTEMPORARY AND COLONIAL POLES | | | | | |
| DRAWN | CHECKED | DATE | | | | | | |
| C.A. | L.D. | 21-07 | | CD 300-1 | | | SHT | REV |
| | | | | 0001 OF 1 | | | 04 | |

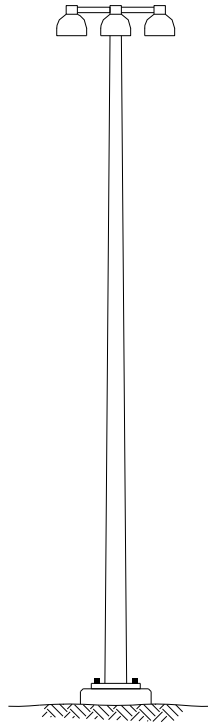

HI-MAST

| POLE TYPE | COLOUR | MOUNTING HEIGHT m (ft) | ARM REACH m | BOLT SQUARE mm | BOLT CIRCLE mm | STORES CODE NO. | CABLE LENGTH m |
|-----------|------------|---------------------------|----------------|-------------------|-------------------|-----------------|-------------------|
| HI-MAST | GALVANIZED | 30.5 (100) | N/A | PER DESIGN | PER DESIGN | N/A | N/A |

NOTE:

HI-MAST POLES ARE DESIGNED PER INSTALLATION.

SUPERCEDES ORIGINAL SEALED BY E. WIEBE ON 89-04-28

| | | | | | | | |
|--|-----------------|---------------|--|-----------------|--|------------------|-----------|
| APPROVED | | REVISIONS | | | MANITOBA HYDRO DISTRIBUTION STANDARDS | | |
| ORIGINAL DRAWING SEALED BY J.J.D. RINGASH 18-05-11 | 21-07 | 3 | REMOVED STRAIGHT SHAFT, UPDATED NOTES | | NON-STANDARD STREET LIGHT POLES | | |
| | 18-04 | 2 | ADDED SHEET 2, TABLE & NOTES, RESEALED | | | | |
| | 92-11 | 1 | CHANGE ALUM. TO STEEL ARM | | | | |
| DRAWN C.A. | CHECKED J.R. | DATE 18-04 | | CD 300-2 | | SHT 0001 of 2 | REV 03 |

THERE ARE A NUMBER OF STYLES AND TYPES OF STREET LIGHT POLES WHICH HAVE BEEN USED, IN LIMITED QUANTITIES, IN ORDER TO MEET ROADWAY LIGHTING REQUIREMENTS IN SPECIAL CIRCUMSTANCES.

DAVIT TYPE STREET LIGHT POLES WITH DOUBLE AND TRIPLE ARM ARRANGEMENTS HAVE BEEN PURCHASED TO LIGHT INTERSECTIONS WITH UNUSUAL ROADWAY CONFIGURATIONS. STRAIGHT SHAFT ALUMINUM POLES WITH TAPERED ALUMINUM BRACKET ARMS HAVE BEEN USED FOR BRIDGE LIGHTING AND IN OTHER CIRCUMSTANCES, PRIMARILY FOR ESTHETIC REASONS.

SPECIAL STREET LIGHT POLES HAVE BEEN USED AT LARGE HIGHWAY INTERCHANGES AND ON MAJOR ROADWAYS WHERE HIGHER MOUNTING HEIGHTS CAN BE USED EFFECTIVELY TO DRASTICALLY REDUCE THE NUMBER OF POLES WHICH WOULD OTHERWISE BE REQUIRED. THE TWO MOST COMMON STYLES OF POLES USED TO ACHIEVE SUCH HIGHER MOUNTING HEIGHTS (i.e. 16.8m, 19.8m AND 30.5m).

NON-STANDARD STREET LIGHT POLES ARE, ON OCCASION, AVAILABLE FROM CENTRAL STORES, BUT GENERALLY, NON-STANDARD STREET LIGHT POLES MUST BE PURCHASED AS REQUIRED.

| | | | | | | |
|--|-----------------|---------------|--|--|------------------|-----------|
| APPROVED ORIGINAL DRAWING SEALED BY J.J.D. RINGASH 18-05-11 | REVISIONS | | MANITOBA HYDRO DISTRIBUTION STANDARDS <p style="text-align: center;">NON-STANDARD STREET LIGHT POLES</p> | | | |
| DRAWN C.A. | CHECKED L.D. | DATE 18-04 | <p style="text-align: center;">CD 300-2</p> | | SHT 0002 of 2 | REV 00 |

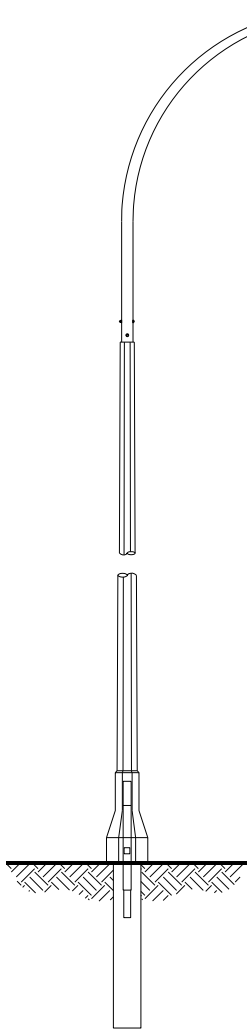

DAVIT DB
(DIRECT BURIAL)

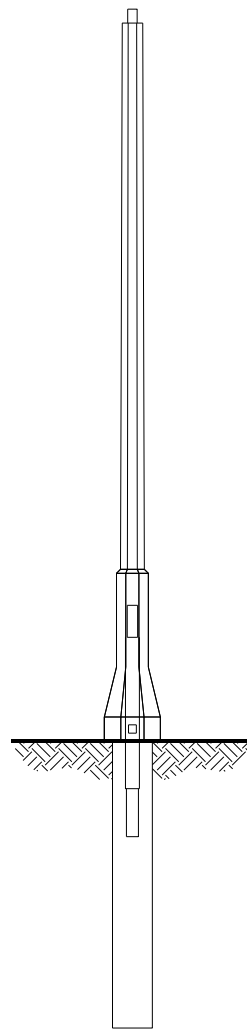

POST-TOP DB
(DIRECT BURIAL)

| POLE TYPE | COLOUR | MOUNTING HEIGHT m (ft) | ARM REACH m | STORES CODE NO. | CABLE LENGTH m * |
|-------------|--------|---------------------------|----------------|-----------------|---------------------|
| POST-TOP DB | BLACK | 4.7 (15) | N/A | 03 67 39 | 6 |
| DAVIT DB | BLACK | 11.3 (37) | 3.0 | 03 65 29 | 15 |
| DAVIT DB | BLACK | 13.7 (45) | 3.0 | 03 65 30 | 18 |

NOTES:

* LENGTH OF 2 CONDUCTORS #12 CABLE REQUIRED PER POLE.

| | | | | | | | | | |
|--|----------------------|---------------|-----------------|---|--|-----|-----|-----------|----|
| APPROVED | | REVISIONS | | MANITOBA HYDRO DISTRIBUTION STANDARDS | | | | | |
| ORIGINAL DRAWING SEALED BY D.R. ORR 13-02-12 | | | | STANDARD CONCRETE STREET LIGHT POLES | | | | | |
| DRAWN C.A. | CHECKED L.D./D.O. | DATE 13-01 | CD 300-3 | | <table border="1"> <tr> <td>SHT</td> <td>REV</td> </tr> <tr> <td>0001 of 1</td> <td>00</td> </tr> </table> | SHT | REV | 0001 of 1 | 00 |
| SHT | REV | | | | | | | | |
| 0001 of 1 | 00 | | | | | | | | |

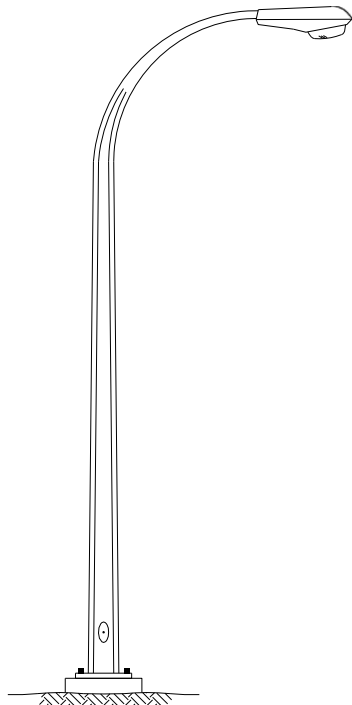

DAVIT BM
(BASE MOUNTED)

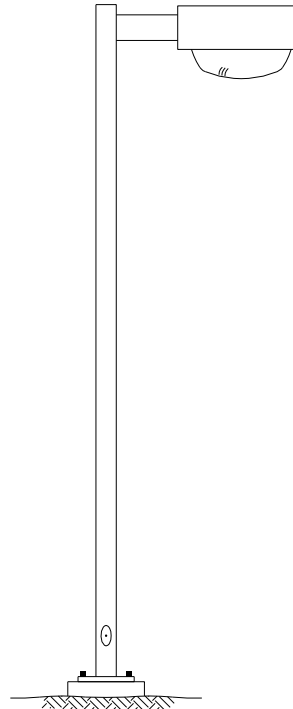

SQUARE BM
(BASE MOUNTED)

| POLE TYPE | COLOUR | MOUNTING HEIGHT m (ft) | ARM REACH m | BOLT SQUARE mm | BOLT CIRCLE mm | STORES CODE NO. | CABLE LENGTH m |
|-----------|-------------|---------------------------|----------------|-------------------|-------------------|-----------------|-------------------|
| DAVIT BM | GALVANIZED | 7.7 (25) | 1.8 | 179 | 254 | 75 42 26 | 11 |
| DAVIT BM | GALVANIZED | 9.1 (30) | 2.4 | 197 | 279 | 75 43 30 | 13 |
| DAVIT BM | GALVANIZED | 10.7 (35) | 3.0 | 206 | 292 | 75 44 36 | 15 |
| DAVIT BM | GALVANIZED | 13.7 (45) | 3.0 | 243 | 343 | 75 46 45 | 18 |
| SQUARE BM | DARK BRONZE | 6.1 (20) | 0.5 | 179 | 254 | 75 42 20 | 8 |
| SQUARE BM | DARK BRONZE | 10.7 (35) | 0.5 | 206 | 292 | 75 45 30 | 14 |

| | | | | | | | | | |
|--|-----------------|---------------|-----------------|--|--|-----|-----|-----------|----|
| APPROVED | | REVISIONS | | MANITOBA HYDRO DISTRIBUTION STANDARDS | | | | | |
| ORIGINAL DRAWING SEALED BY J.J.D. RINGASH 21-07-30 | | | | DISCONTINUED STREET LIGHT POLES | | | | | |
| DRAWN C.A. | CHECKED L.D. | DATE 21-07 | CD 300-4 | | <table border="1"> <tr> <td>SHT</td> <td>REV</td> </tr> <tr> <td>0001 of 1</td> <td>00</td> </tr> </table> | SHT | REV | 0001 of 1 | 00 |
| SHT | REV | | | | | | | | |
| 0001 of 1 | 00 | | | | | | | | |

7.7 - 10.7 STREET LIGHT POLES

NOTES:

1. FOR FUTURE ACCESS TO LOWER PORTION OF PLASTIC PIPE, LOCATE "V" GROOVE SIDE OF BASE TO ROADWAY PROVIDED THAT:
 - a) A MIN. HORIZONTAL SEPARATION OF 350mm IS MAINTAINED TO ANY PAVED SURFACE OR STRUCTURE; OR
 - b) IF LESS THAN 350mm, ROTATE BASE 90°
2. ROUTE UNDERGROUND CABLES DIRECTLY INTO PLASTIC PIPE.
3. IN BACKFILL AREA, ENCASE UNDERGROUND CABLES IN A 75mm RADIUS ENVELOPE OF EXCAVATED MATERIAL OR SAND TO PROTECT CABLES. DO NOT BACKFILL WITH EXCAVATED MATERIAL OR SAND MORE THAN 1/6 OF THE WAY AROUND BASE.
4. SEE CD300-9 FOR ANCHOR ROD TIGHTENING METHOD.
5. DIMENSIONS SHOWN ARE MILLIMETRES.

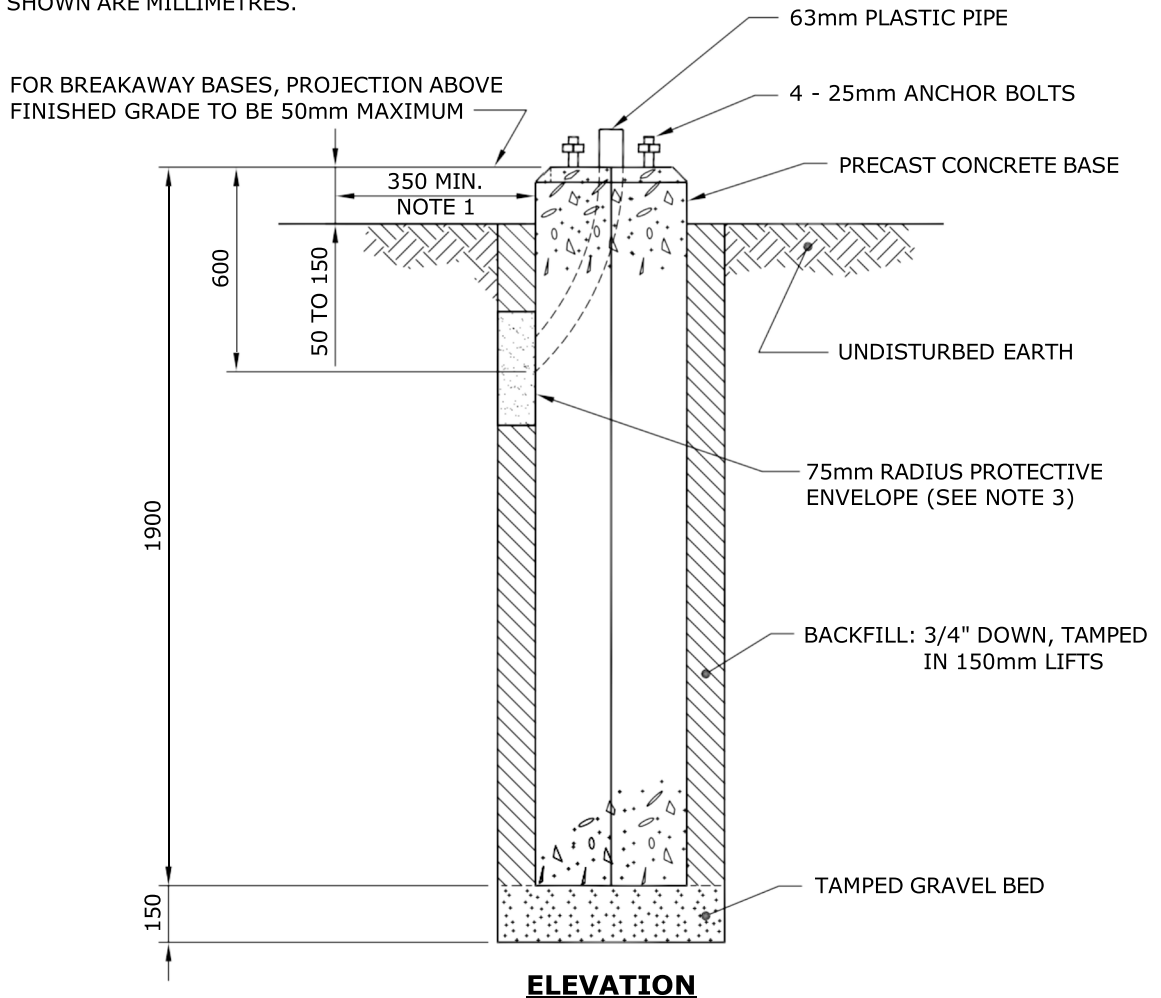
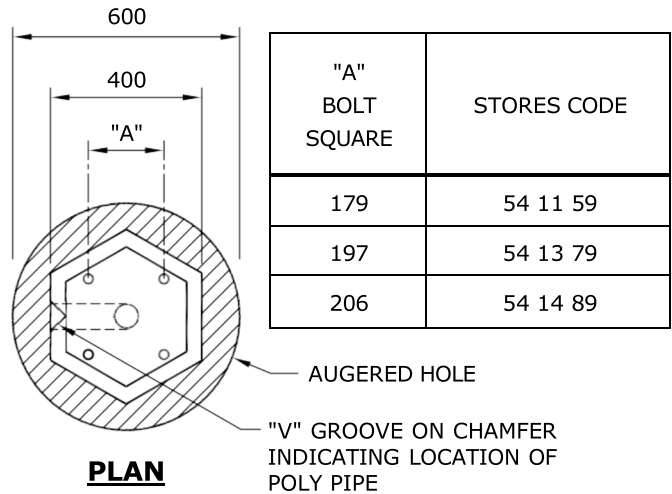

| | | | | |
|--|------------------------|---------------|---|------------------|
| APPROVED | REVISIONS | | MANITOBA HYDRO DISTRIBUTION STANDARDS | |
| ORIGINAL DRAWING SEALED BY E.H. WIEBE 89-04-29 | 10-08 | 3 | CHANGED BACKFILL NOTES, AND ADDED SHEET 3 | |
| | 99-05 | 1 | SHEET 2 of 2 ADDED, 7.7 - 10.7 STREET LIGHT ADDED | |
| | 96-10 | 1 | V-GROOVE LOCATION, POLY PIPE SIZE NOTES CHANGED | |
| DRAWN W.B./CAD | CHECKED L.D./K.C.H. | DATE 88-06 | INSTALLATION OF PRECAST CONCRETE BASE | |
| | | | CD 300-6 | SHT 0001 of 3 |
| | | | REV 03 | |

13.7 STREET LIGHT POLE

NOTES:

1. FOR FUTURE ACCESS TO LOWER PORTION OF PLASTIC PIPE, LOCATE "V" GROOVE SIDE OF BASE TO ROADWAY PROVIDED THAT:
 - a) A MIN. HORIZONTAL SEPARATION OF 350mm IS MAINTAINED TO ANY PAVED SURFACE OR STRUCTURE; OR
 - b) IF LESS THAN 350mm, ROTATE BASE 90°
2. ROUTE UNDERGROUND CABLES DIRECTLY INTO PLASTIC PIPE.
3. IN BACKFILL AREA, ENCASE UNDERGROUND CABLES IN A 75mm RADIUS ENVELOPE OF EXCAVATED MATERIAL OR SAND TO PROTECT CABLES. DO NOT BACKFILL WITH EXCAVATED MATERIAL OR SAND MORE THAN 1/6 OF THE WAY AROUND BASE.
4. SEE CD300-9 FOR ANCHOR ROD TIGHTENING METHOD.
5. DIMENSIONS SHOWN ARE MILLIMETRES.

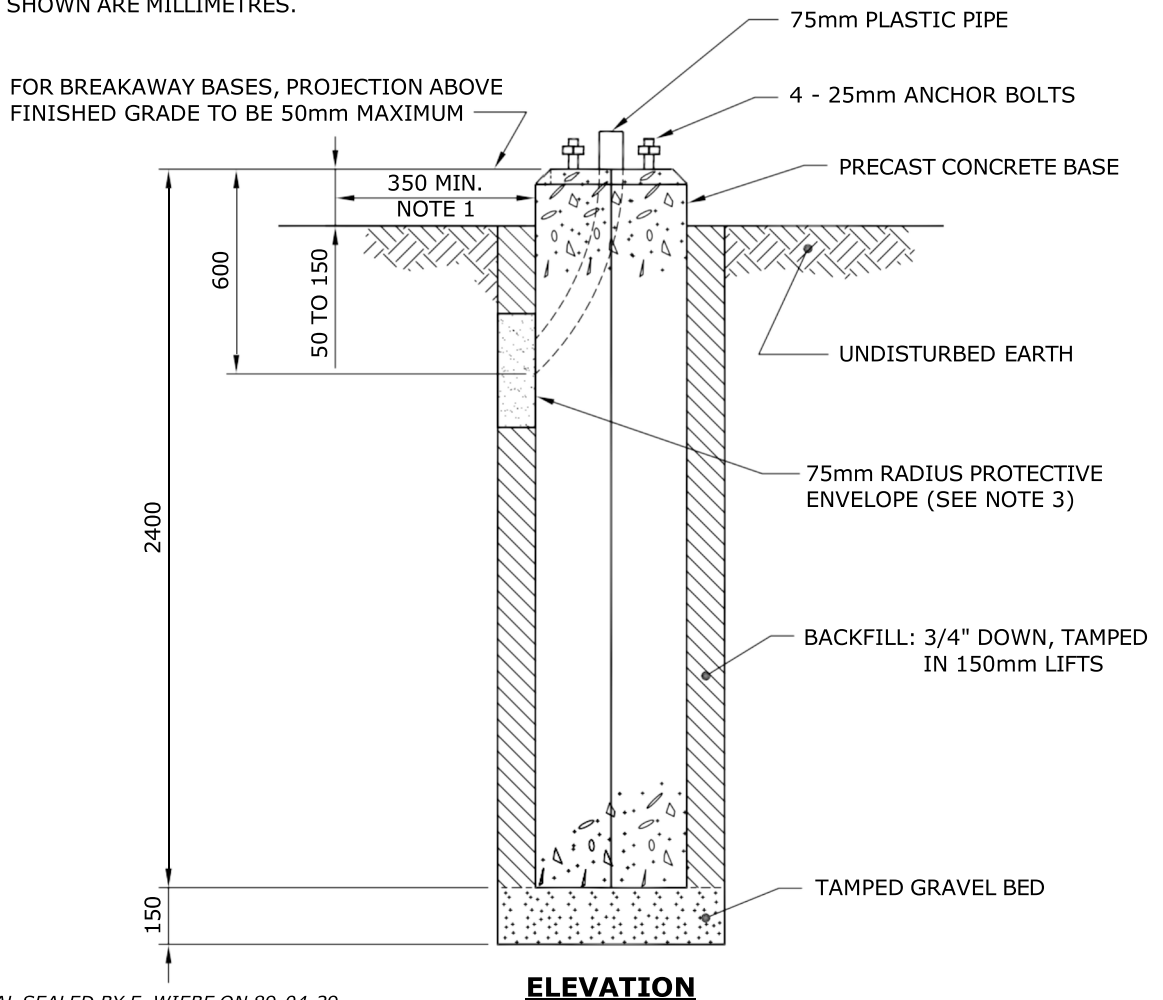
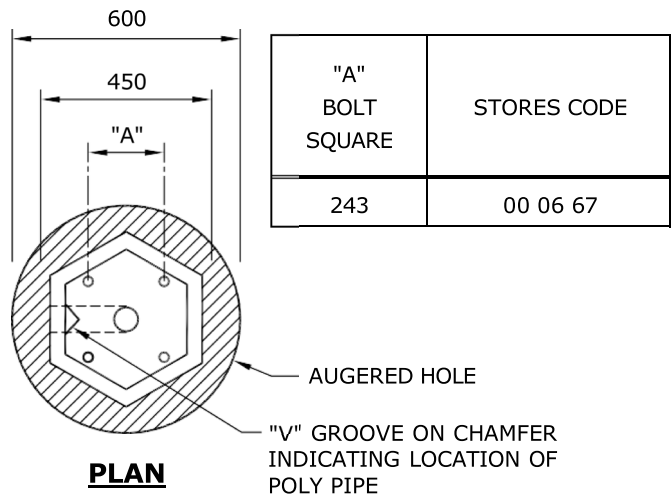

SUPERCEDES ORIGINAL SEALED BY E. WIEBE ON 89-04-29

| | | | | |
|--|-----------------|---------------|---|----|
| APPROVED | REVISIONS | | MANITOBA HYDRO DISTRIBUTION STANDARDS | |
| ORIGINAL DRAWING SEALED BY J.J.D. RINGASH 23-01-31 | 23-01 | 2 | ADDED 50mm NOTE FOR BREAKAWAY BASES, RESEALED | |
| | 10-08 | 1 | CHANGED BACKFILL NOTES, AND ADDED SHEET 3 | |
| | | | INSTALLATION OF PRECAST CONCRETE BASE | |
| CD 300-6 | SHT | REV | | |
| DRAWN C.A. | CHECKED L.D. | DATE 23-01 | 0002 OF 3 | 02 |

16.8m & 19.8m STREET LIGHT POLE

NOTES:

1. FOR FUTURE ACCESS TO LOWER PORTION OF PLASTIC PIPE, LOCATE "V" GROOVE SIDE OF BASE TO ROADWAY PROVIDED THAT:
 - a) A MIN. HORIZONTAL SEPARATION OF 350mm IS MAINTAINED TO ANY PAVED SURFACE OR STRUCTURE; OR
 - b) IF LESS THAN 350mm, ROTATE BASE 90°
2. ROUTE UNDERGROUND CABLES DIRECTLY INTO PLASTIC PIPE.
3. IN BACKFILL AREA, ENCASE UNDERGROUND CABLES IN A 75mm RADIUS ENVELOPE OF EXCAVATED MATERIAL OR SAND TO PROTECT CABLES. DO NOT BACKFILL WITH EXCAVATED MATERIAL OR SAND MORE THAN 1/6 OF THE WAY AROUND BASE.
4. SEE CD300-9 FOR ANCHOR ROD TIGHTENING METHOD.
5. DIMENSIONS SHOWN ARE MILLIMETRES.

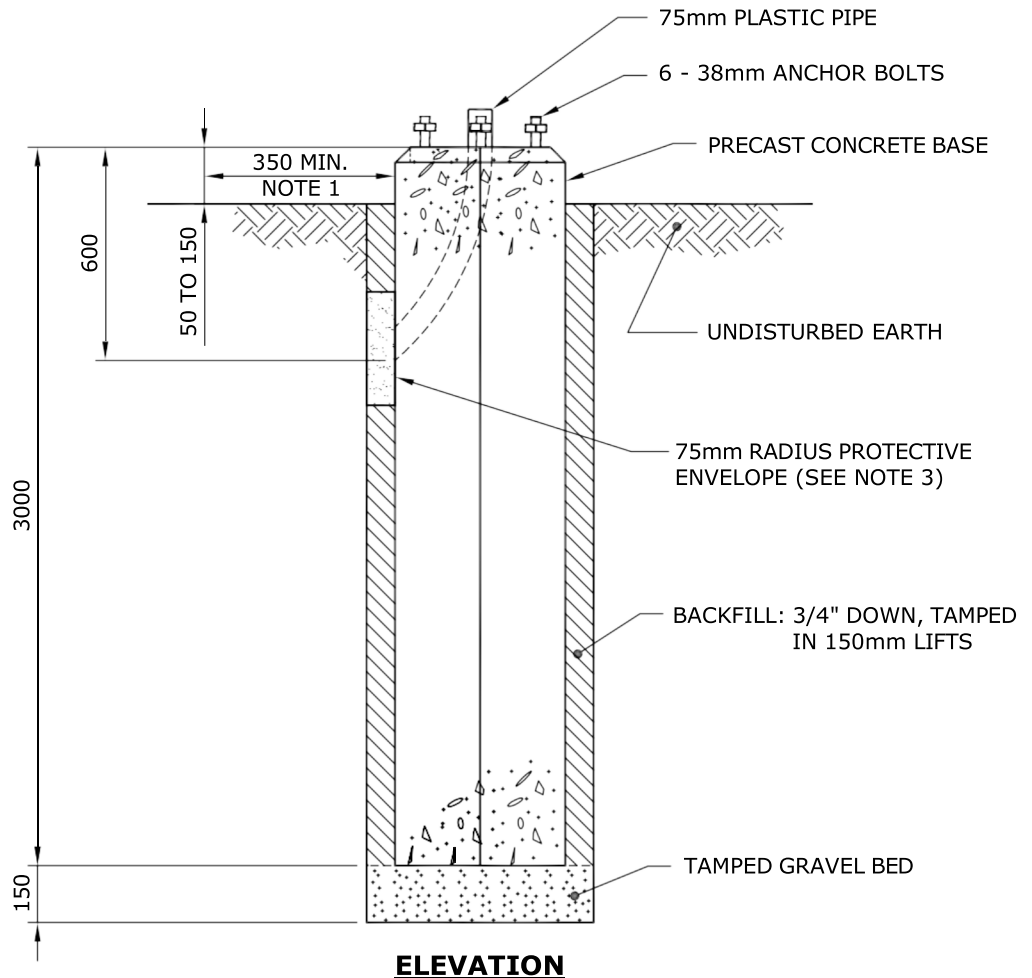
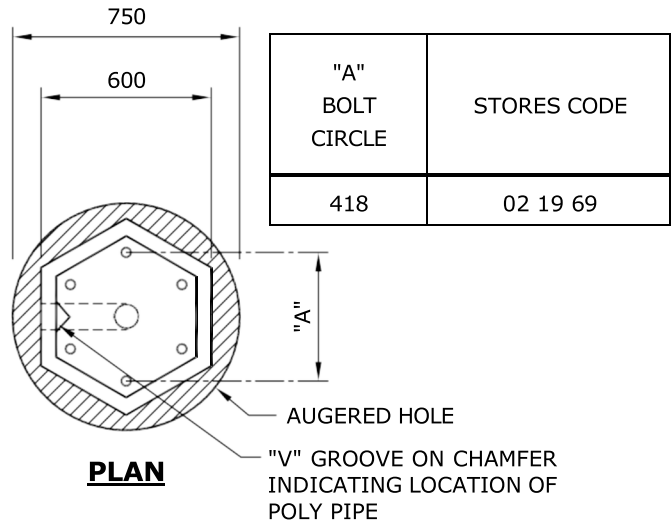

| | | | |
|---|------------------------|--|-----------------|
| APPROVED | REVISIONS | MANITOBA HYDRO DISTRIBUTION STANDARDS | |
| ORIGINAL DRAWING SEALED BY K.C. HAMILTON 10-08-13 | | INSTALLATION OF PRECAST CONCRETE BASE | |
| DRAWN C.A. | CHECKED L.D./K.C.H. | DATE 10-08 | CD 300-6 |
| | | SHT 0003 OF 3 | REV 00 |

7.7 - 10.7 STREET LIGHT POLES

NOTES:

1. FOR FUTURE ACCESS TO LOWER PORTION OF PLASTIC PIPE, LOCATE "V" GROOVE SIDE OF BASE TO ROADWAY PROVIDED THAT:
 - a) A MIN. HORIZONTAL SEPARATION OF 350mm IS MAINTAINED TO ANY PAVED SURFACE OR STRUCTURE; OR
 - b) IF LESS THAN 350mm, ROTATE BASE 90°
2. ROUTE UNDERGROUND CABLES DIRECTLY INTO PLASTIC PIPE.
3. IN BACKFILL AREA, ENCASE UNDERGROUND CABLES IN A 75mm RADIUS ENVELOPE OF EXCAVATED MATERIAL OR SAND TO PROTECT CABLES. DO NOT BACKFILL WITH EXCAVATED MATERIAL OR SAND MORE THAN 1/6 OF THE WAY AROUND BASE.
4. SEE CD300-9 FOR ANCHOR ROD TIGHTENING METHOD.
5. INSTALL EXPANDING POLE KEY ANCHOR PER CD44-30. ENSURE TOP ANCHOR DOES NOT OBSTRUCT CONDUIT ENTRY HOLE.
6. FINISHED GRADE TO BE LEVEL FOR A MINIMUM OF 600mm AROUND BASE.
7. DIMENSIONS SHOWN ARE MILLIMETRES.

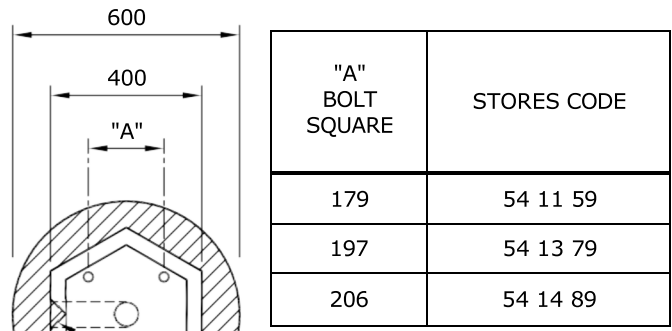

PLAN

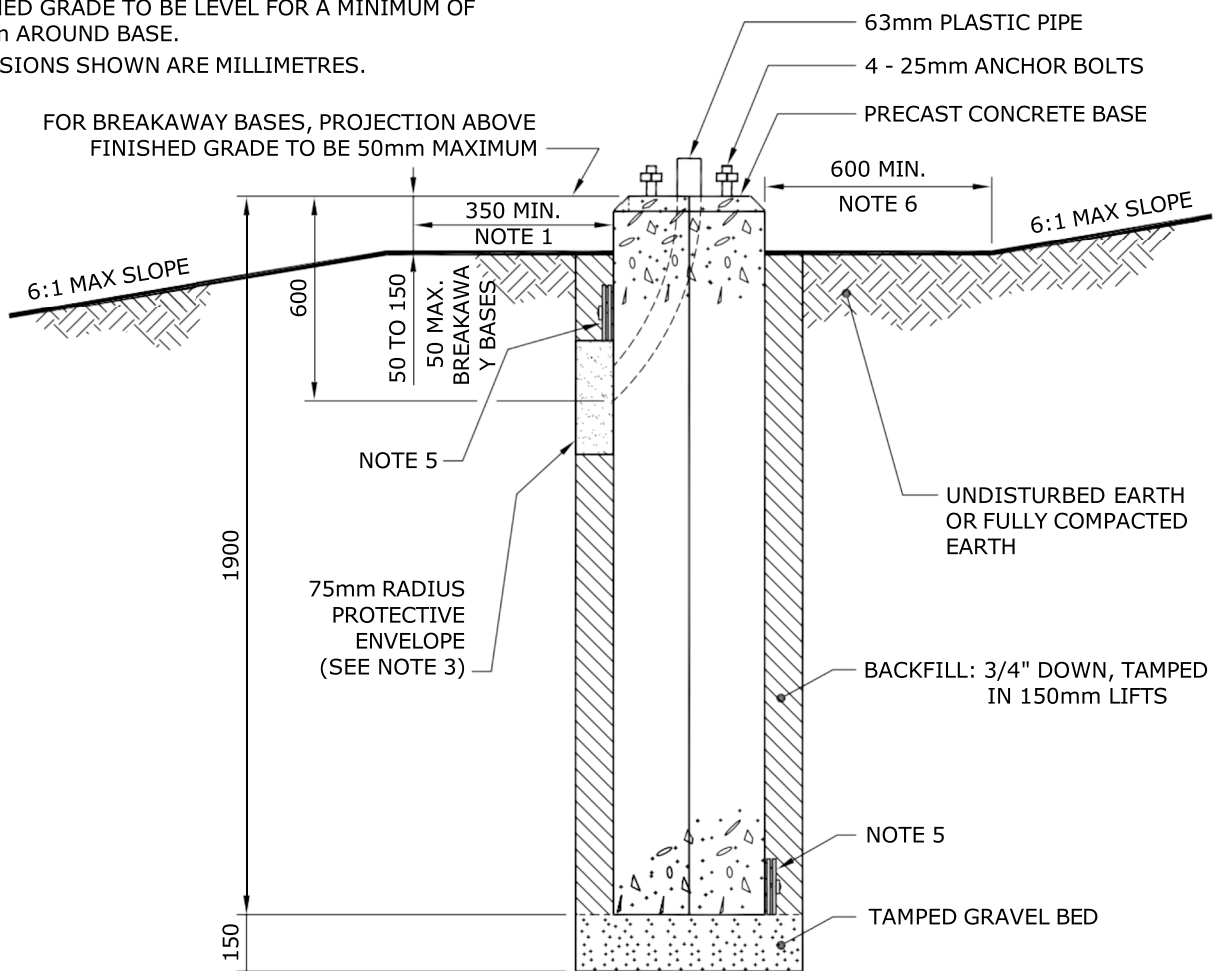

ELEVATION

| | | | | |
|--|-----------------|---------------|---|-----------|
| APPROVED | REVISIONS | | MANITOBA HYDRO DISTRIBUTION STANDARDS | |
| ORIGINAL DRAWING SEALED BY J.J.D. RINGASH 19-10-08 | | | INSTALLATION OF PRECAST CONCRETE BASE ON SLOPE | |
| DRAWN C.A. | CHECKED L.D. | DATE 19-10 | CD 300-7 | |
| | | | SHT 0001 OF 2 | REV 00 |

13.7 STREET LIGHT POLE

NOTES:

1. FOR FUTURE ACCESS TO LOWER PORTION OF PLASTIC PIPE, LOCATE "V" GROOVE SIDE OF BASE TO ROADWAY PROVIDED THAT:
 - a) A MIN. HORIZONTAL SEPARATION OF 350mm IS MAINTAINED TO ANY PAVED SURFACE OR STRUCTURE; OR
 - b) IF LESS THAN 350mm, ROTATE BASE 90°
2. ROUTE UNDERGROUND CABLES DIRECTLY INTO PLASTIC PIPE.
3. IN BACKFILL AREA, ENCASE UNDERGROUND CABLES IN A 75mm RADIUS ENVELOPE OF EXCAVATED MATERIAL OR SAND TO PROTECT CABLES. DO NOT BACKFILL WITH EXCAVATED MATERIAL OR SAND MORE THAN 1/6 OF THE WAY AROUND BASE.
4. SEE CD300-9 FOR ANCHOR ROD TIGHTENING METHOD.
5. INSTALL EXPANDING POLE KEY ANCHOR PER CD44-30. ENSURE TOP ANCHOR DOES NOT OBSTRUCT CONDUIT ENTRY HOLE.
6. FINISHED GRADE TO BE LEVEL FOR A MINIMUM OF 600mm AROUND BASE.
7. DIMENSIONS SHOWN ARE MILLIMETRES.

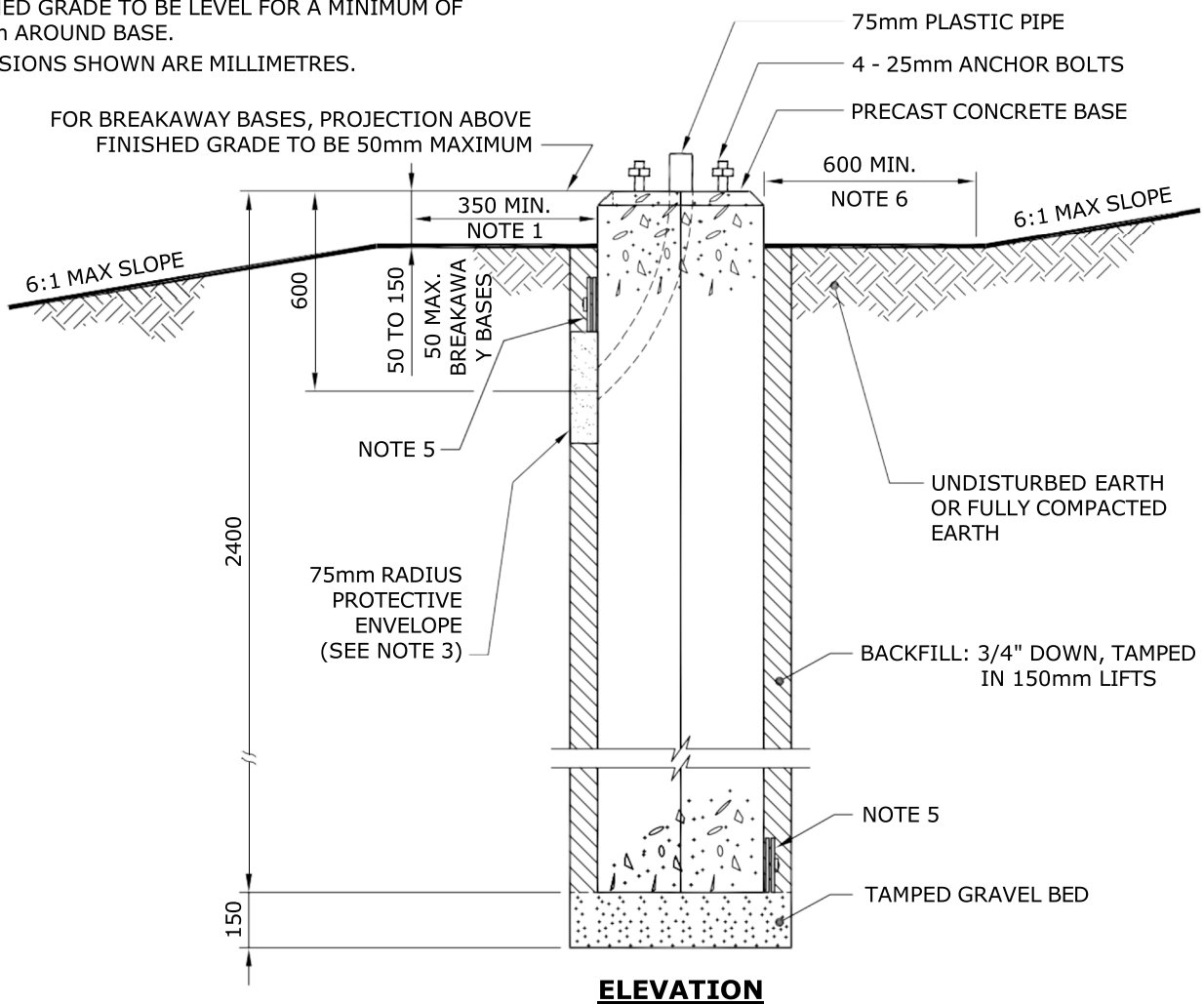
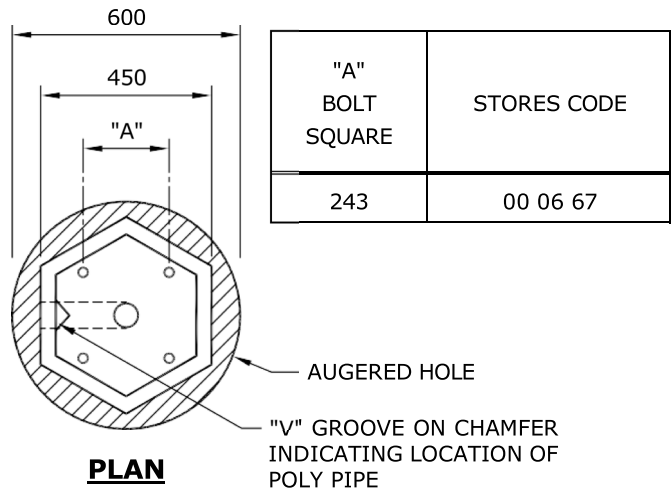

| | | | | |
|--|-----------------|---------------|---|-----------|
| APPROVED | REVISIONS | | MANITOBA HYDRO DISTRIBUTION STANDARDS | |
| ORIGINAL DRAWING SEALED BY J.J.D. RINGASH 19-10-08 | | | INSTALLATION OF PRECAST CONCRETE BASE ON SLOPE | |
| DRAWN C.A. | CHECKED L.D. | DATE 19-10 | CD 300-7 | |
| | | | SHT 0002 OF 2 | REV 00 |

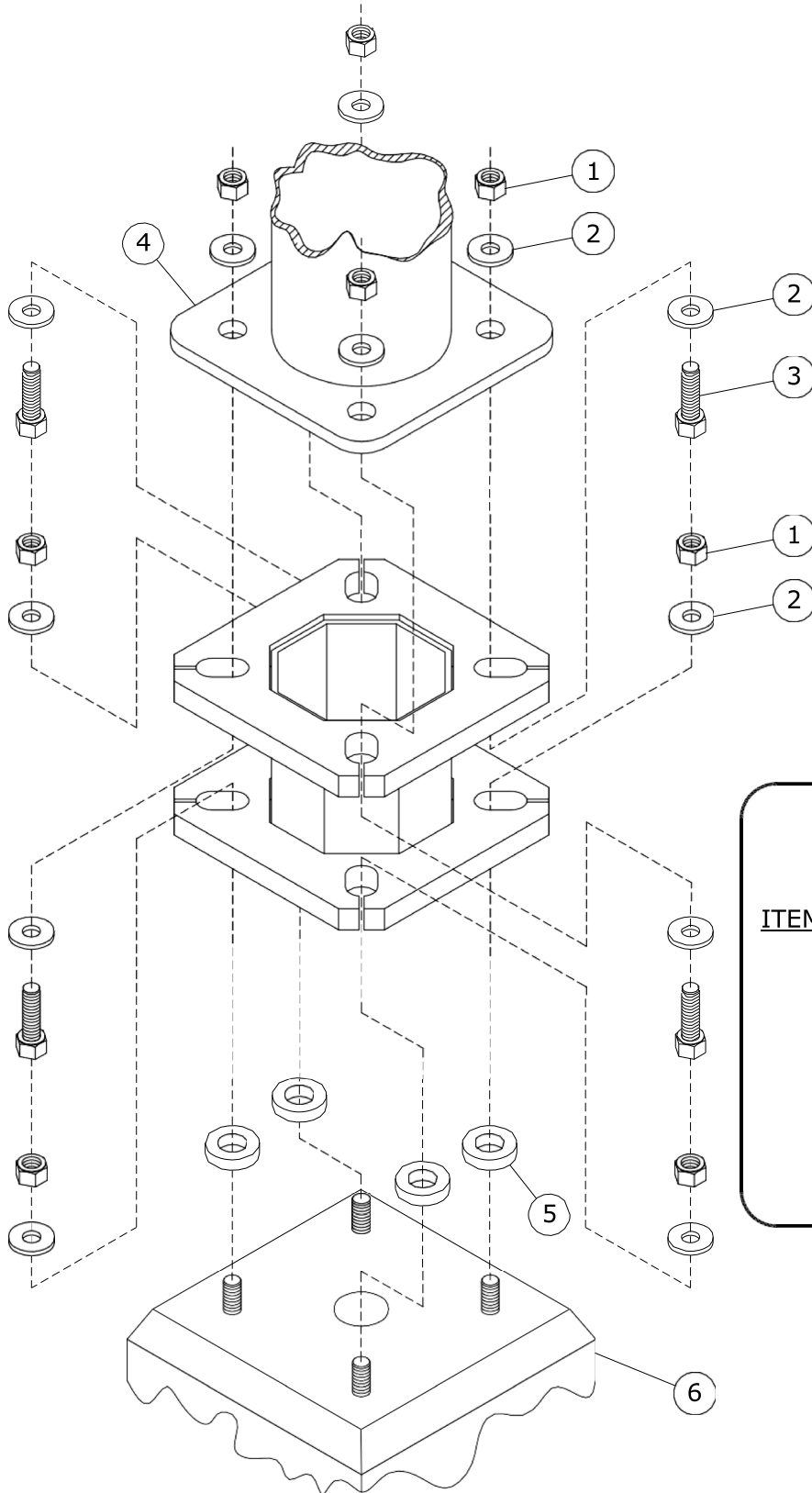

MATERIAL LIST

| <u>ITEM No.</u> | <u>DESCRIPTION</u> |
|-----------------|---------------------|
| 1. | NUT 1" - UNC |
| 2. | WASHER 1" |
| 3. | BOLT 1" - UNC |
| 4. | LIGHT STANDARD |
| 5. | SHIMS - AS REQUIRED |
| 6. | FOUNDATION |

CIIC# 04 92 81

| | | | | | |
|--|-----------------|---------------|-----------------|--|-----|
| APPROVED | | REVISIONS | | MANITOBA HYDRO DISTRIBUTION STANDARDS | |
| ORIGINAL DRAWING SEALED BY J.J.D. RINGASH 19-10-08 | | | | ANCHOR BASE ADAPTER INSTALLATION 254mm BCD TO 292mm BCD (4.7m TO 10.7m STANDARDS) | |
| DRAWN C.A. | CHECKED L.D. | DATE 19-10 | CD 300-8 | | |
| | | | SHT | | REV |
| | | | 0001 of 2 | | 00 |

APPLICATIONS:

1. ANCHOR ROD TO ANCHOR ROD HOLE MISALIGNMENT.
2. FOUNDATION EXTENSION TO RAISE BURIED ANCHOR BASE OF LIGHT STANDARD TO GRADE.

RESTRICTIONS:

1. INSTALL ONLY GOOD LIGHT STANDARDS ON GOOD FOUNDATIONS AS PER CORPORATE POLICIES P348-4, "REPLACING ORNAMENTAL LIGHT STANDARDS", AND P348-5, "REPLACING OR RESETTING CONCRETE FOUNDATIONS".
2. INSTALL THE SAME TYPE OF LIGHT STANDARD AS PREVIOUS.
3. FOUR STANDARDS MOUNTED ON 179, 197, AND 206 BASES ONLY. POST TOP OR SINGLE ARM LIGHT STANDARDS OF MAXIMUM HEIGHT 10.7m (35').
4. ONLY ONE ADAPTER PLATE PER LIGHT STANDARD IS ALLOWED, DO NOT STACK.

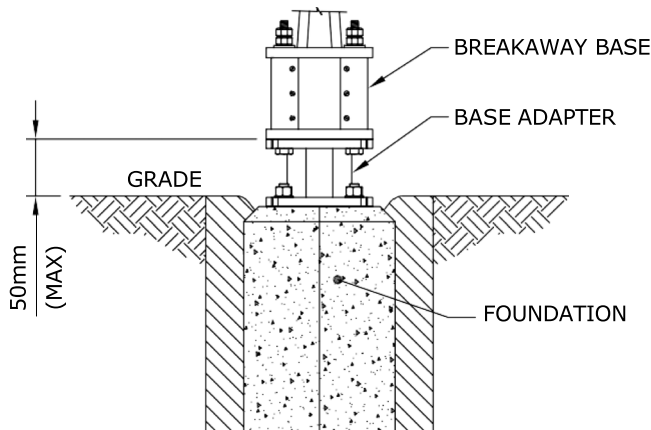

FOUNDATION EXTENSION WITH BREAKAWAY BASE

BREAKAWAY BASES:

1. MAXIMUM ELEVATION OF BOTTOM OF BREAKAWAY BASE IS 50mm AS SHOWN.

ANCHORING:

1. LEVELING SHIMS ARE TO BE USED BETWEEN THE FOUNDATION AND BASE ADAPTER (WHEN REQUIRED).
2. ALL ANCHORING CONNECTIONS ARE TO BE TIGHTENED PER CD300-9, "METHOD FOR ANCHOR ROD TIGHTENING".

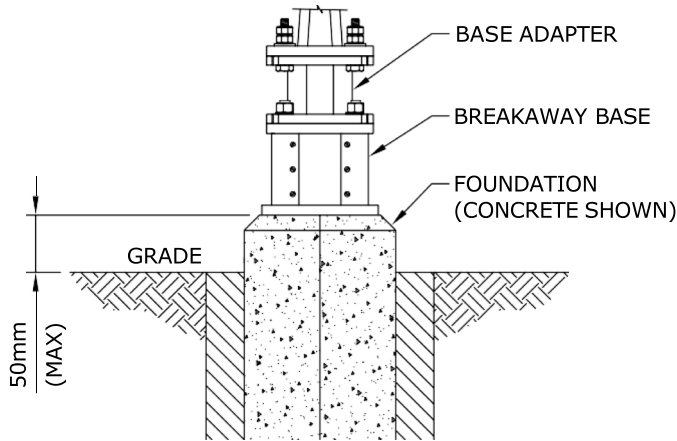

ANCHORAGE MISALIGNMENT WITH BREAKAWAY BASE

| | | | | | |
|--|-----------------|---------------|-----------------|--|--|
| APPROVED | | REVISIONS | | MANITOBA HYDRO DISTRIBUTION STANDARDS | |
| ORIGINAL DRAWING SEALED BY J.J.D. RINGASH 19-10-08 | | | | ANCHOR BASE ADAPTER INSTALLATION 254mm BCD TO 292mm BCD (4.7m TO 10.7m STANDARDS) | |
| DRAWN C.A. | CHECKED L.D. | DATE 19-10 | CD 300-8 | | |
| | | | SHT | REV | |
| | | | 0002 of 2 | 00 | |

TO DEVELOP THE REQUIRED TENSION ON ANCHOR RODS, THE TURN-OF-NUT METHOD IS USED.

TURN-OF-NUT

1. ENSURE ALL ANCHOR RODS AND NUTS ARE FREE OF DEBRIS AND THAT THE ANCHOR RODS ARE LUBRICATED.
2. PLACE POLE ONTO CONCRETE PILE, INSTALL WASHERS AND NUTS AND TIGHTEN UNTIL DEVELOPING A SNUG-TIGHTENED CONNECTION.

SNUG-TIGHTENED: THE TIGHTNESS THAT IS ATTAINED AFTER A FEW IMPACTS OF AN IMPACT WRENCH OR THE FULL FORCE OF A WORKER USING AN ORDINARY ONE FOOT LONG WRENCH.

3. TIGHTENING OF THE BOLTS MUST BE PERFORMED IN A MANNER THAT BRINGS THE FAYING SURFACES UP "EVENLY" AS PER THE STAR PATTERN TIGHTENING SEQUENCE.

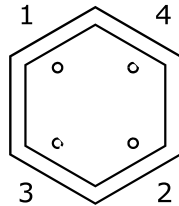

FOUR ANCHOR BOLT PATTERN
(13.7m AND BELOW)

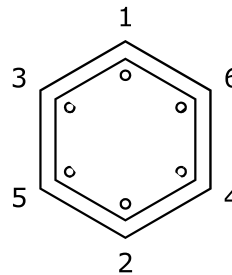

SIX ANCHOR BOLT PATTERN
(16.8m AND 19.8m)

4. ENSURE THE POLE IS PLUMB AND ADD LEVELING SHIMS IF REQUIRED. SNUG-TIGHTEN THE ANCHOR BOLTS AGAIN.
5. BEVELED WASHERS ARE REQUIRED IF THE NUT CANNOT BE BROUGHT INTO FIRM CONTACT WITH THE BASE PLATE.
6. MARK THE REFERENCE LOCATION OF THE NUT AFTER SNUG-TIGHTENING THE PLUMB POLE.
7. FINAL TIGHTENING OF NUTS IS PERFORMED IN INCREMENTS AS PER THE STAR PATTERN, WITH A MINIMUM OF TWO FULL TIGHTENING CYCLES. PROPER TENSIONING IS ACHIEVED WHEN THE NUT IS ROTATED 1/3 OF A TURN BEYOND SNUG-TIGHT. THE TOLERANCE FOR THIS IS PLUS 20°.

| | | | | |
|---|-----------------|---------------|---|-----------|
| APPROVED | REVISIONS | | MANITOBA HYDRO DISTRIBUTION STANDARDS | |
| ORIGINAL DRAWING SEALED BY K.C. HAMILTON 10-08-13 | | | METHOD FOR ANCHOR ROD TIGHTENING | |
| DRAWN C.A. | CHECKED L.D. | DATE 10-08 | CD 300-9 | |
| | | | SHT 0001 of 1 | REV 00 |

THE FOLLOWING INSTALLATION INSTRUCTIONS ARE APPLICABLE TO NEW OR EXISTING BREAKAWAY BASE INSTALLATIONS ON CONCRETE BASES.

PROCEDURE:

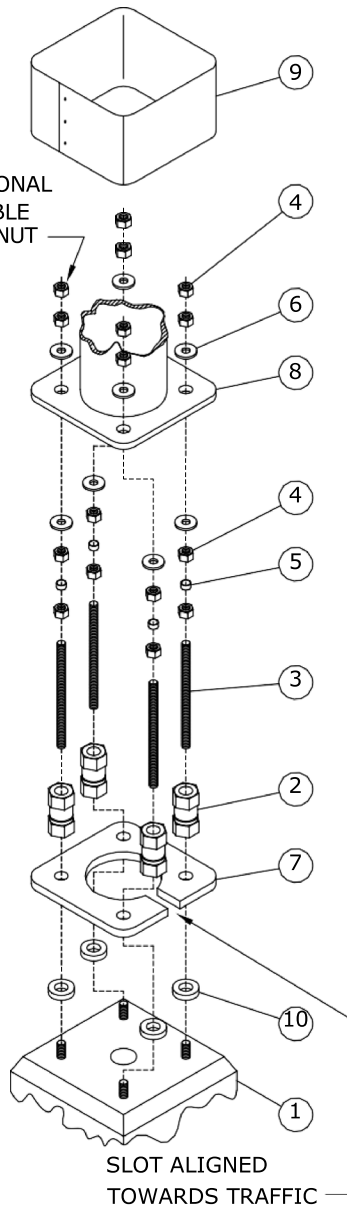

1. CLEAN THE TOP SURFACE OF THE CONCRETE BASE AND ENSURE SURFACE IS FLAT AND LEVEL WITH NO SPALLING OR OTHER SURFACE CONDITIONS THAT MAY AFFECT THE PERFORMANCE OF THE COUPLERS.
 2. THE PREFERRED MAXIMUM HEIGHT ABOVE LEVEL GRADE TO THE BASE OF THE COUPLER IS 50mm OR LESS. THIS PROVIDES THE RECOMMENDED CLEARANCE IN THE EVENT OF A COLLISION WITH THE STRUCTURE.
 3. MEASURE THE HEIGHT OF THE THREADED ANCHOR BOLTS ABOVE THE REACTION PLATE AND VERIFY THIS MEASUREMENT IS BETWEEN 1 1/4" AND 1 5/8".
 4. IF THE EXPOSED LENGTH OF THE ANCHOR BOLT IS GREATER THAN THE RECOMMENDED LENGTH, OPTIONAL SPACERS MAY BE USED (ITEM 10).
 5. IT IS RECOMMENDED THAT THE THREADED ANCHOR BOLT-COUPLER CONNECTION BE COATED WITH RUST-INHIBITING GREASE. THIS WILL FACILITATE REMOVAL OF THE COUPLER WHEN IT IS NECESSARY. A SUITABLE PRODUCT FOR THIS APPLICATION IS ARCAN 1, A WHITE, WATER RESISTANT GREASE MARKETED BY IMPERIAL OIL LTD.
 6. THREAD THE COUPLER ASSEMBLY ON EACH ANCHOR BOLT (IF THE COUPLER ASSEMBLY UPPER STUD BECOMES LOOSE AS A RESULT OF HANDLING, ENSURE THAT THE STUD IS ENGAGED AT LEAST 38mm, BUT NOT MORE THAN 44mm IN THE COUPLER BEFORE LOCKING WITH THE LOCK NUT.)
 7. SNUG UP EACH COUPLER AGAINST THE CONCRETE BASE. TIGHTEN EACH COUPLER ALTERNATELY AND INCREMENTALLY, BY MEANS OF A WRENCH OR A PIPE WRENCH ON THE BOTTOM HEX OF THE COUPLER. USE THE TURN-OF-NUT METHOD AS PER CD300-9.
- NOTE: TIGHTENING THE COUPLER ON THE TOP HEX MAY WEAKEN THE COUPLER AT THE MACHINED GROOVE AND MAKE THE COUPLER UNUSEABLE.**
8. BRING THE LEVELING NUTS (AND HENCE, THE LOWER WASHERS) INTO A LEVEL PLANE AS DESIRED MAKING CERTAIN THAT AT LEAST ONE PLASTIC SPACER REMAINS IN CONTACT WITH ITS LEVELING NUT AND ITS LOCK NUT.
 9. PLACE THE POLE BASE OVER THE PROTRUDING STUDS, AND SECURE THE POLE WITH THE UPPER WASHERS AND RETAINING NUTS.
 10. WITH THE POLE IN THE REQUIRED VERTICAL ORIENTATION, AND BEFORE FINAL TIGHTENING, ENSURE THAT ALL LEVELING NUTS, RETAINING NUTS AND UPPER AND LOWER WASHERS ARE MADE SNUG AGAINST THE POLE BASE PLATE.
 11. TIGHTEN THE RETAINING NUTS WITH THE TURN-OF-NUT METHOD AS PER CD300-9.
 12. MAKE THE NECESSARY WIRING CONNECTIONS, AND INSTALL THE PROTECTIVE SHROUD.

SUPERCEDES ORIGINAL SEALED BY E. WIEBE ON 89-04-28

| | | | | | |
|--|-----------------|---------------|--|---------------------------------------|-----------|
| APPROVED | | REVISIONS | | MANITOBA HYDRO DISTRIBUTION STANDARDS | |
| ORIGINAL DRAWING SEALED BY D.R. ORR 16-06-27 | 16-06 | 4 | CORRECTED TYPO, RESEALED | BREAKAWAY BASE INSTALLATION | |
| | 10-08 | 3 | UPDATED STANDARD, REVISED TITLE, AND ADDED SHEET 2 | | |
| | 07-06 | 2 | REVISED NOTE 4 AND ADDED NOTE 5 | | |
| DRAWN C.A. | CHECKED L.D. | DATE 16-06 | | CD 300-10 | |
| | | | | SHT 0001 of 2 | REV 04 |

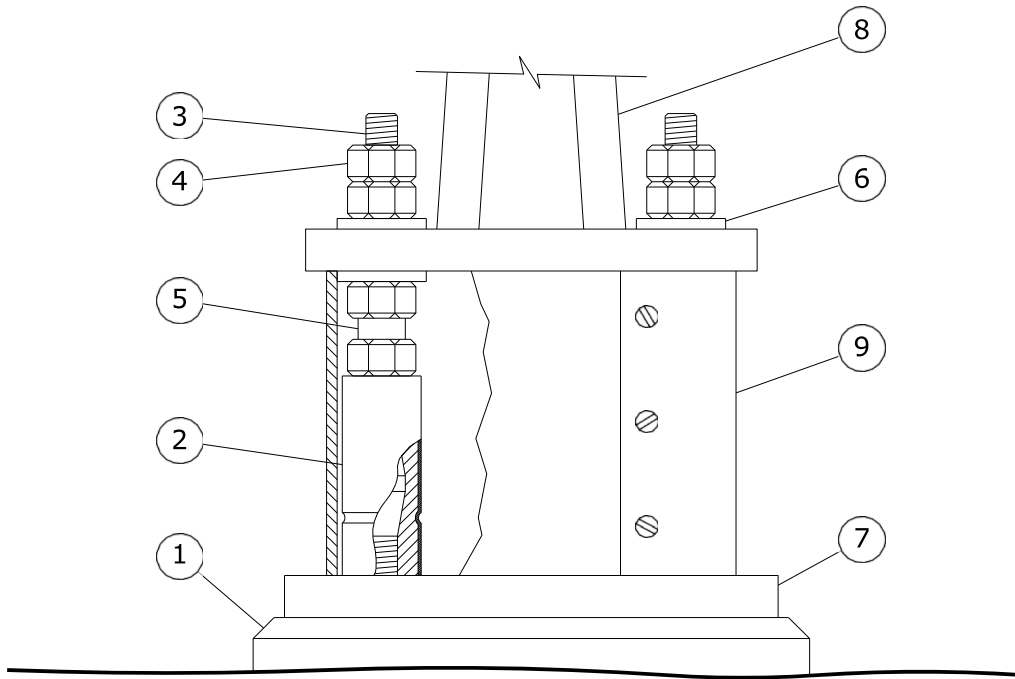

| BILL OF MATERIAL | | |
|------------------|--------------------------------|----------|
| ITEM NO. | DESCRIPTION | QUANTITY |
| 1 | CONCRETE BASE | 1 |
| 2 | COUPLING | 4 |
| 3 | 1" - 8 UNC GALV. STUD | 4 |
| 4 | 1" - 8 UNC GALV. HEAVY HEX NUT | 16 |
| 5 | SPACER | 4 |
| 6 | 1" GALV. FLAT WASHER | 8 |
| 7 | REACTION PLATE | 1 |
| 8 | POLE | 1 |
| 9 | SHROUD ASSEMBLY | 1 |
| 10 | GALV. SHIM | 4 |

| | | | | |
|---|-----------------|---------------|---------------------------------------|-----------|
| APPROVED | REVISIONS | | MANITOBA HYDRO DISTRIBUTION STANDARDS | |
| ORIGINAL DRAWING SEALED BY K.C. HAMILTON 10-08-13 | | | BREAKAWAY BASE INSTALLATION | |
| DRAWN C.A. | CHECKED L.D. | DATE 10-08 | CD 300-10 | |
| | | | SHT 0002 of 2 | REV 00 |

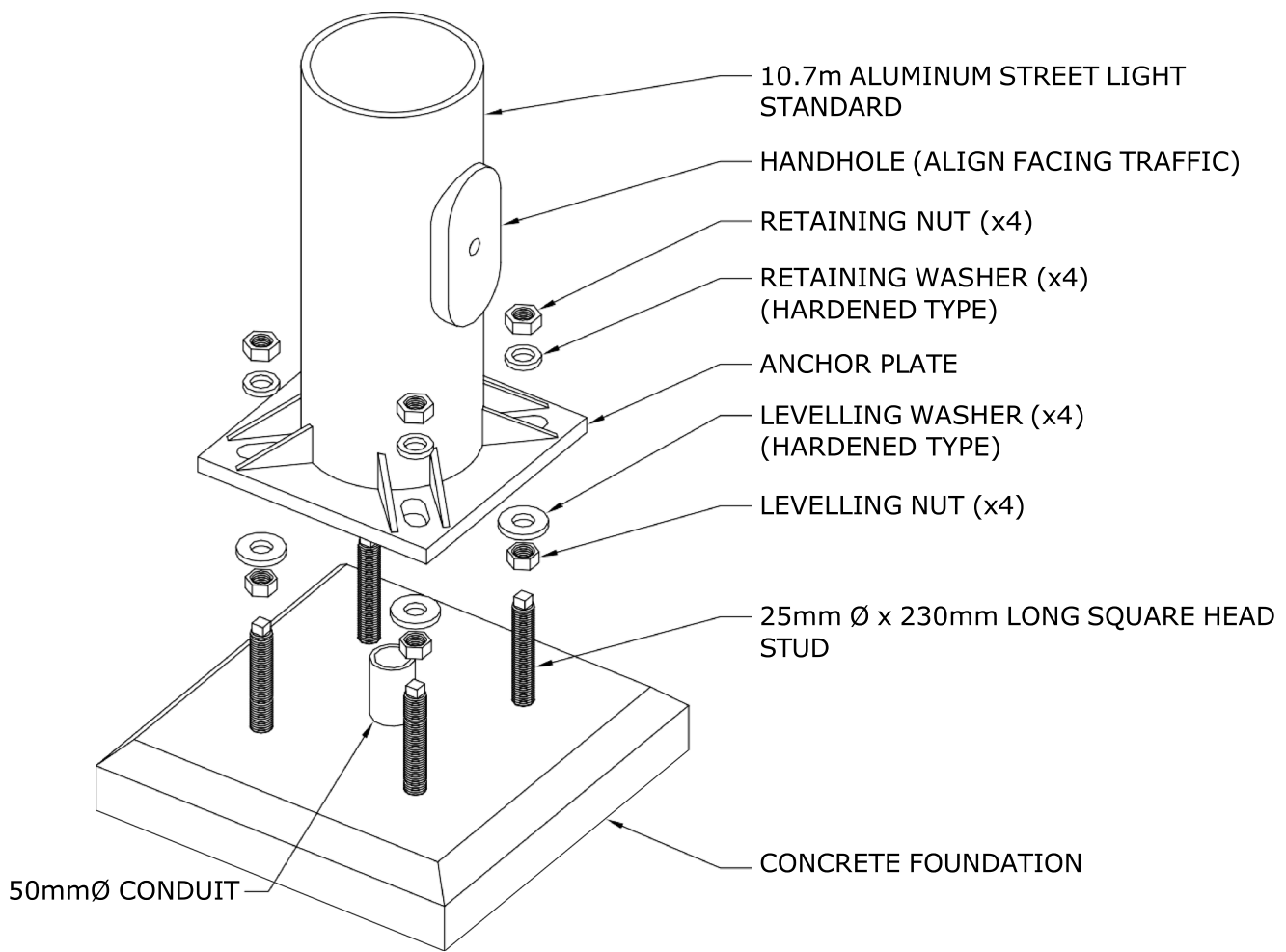

MOUNTING DETAIL

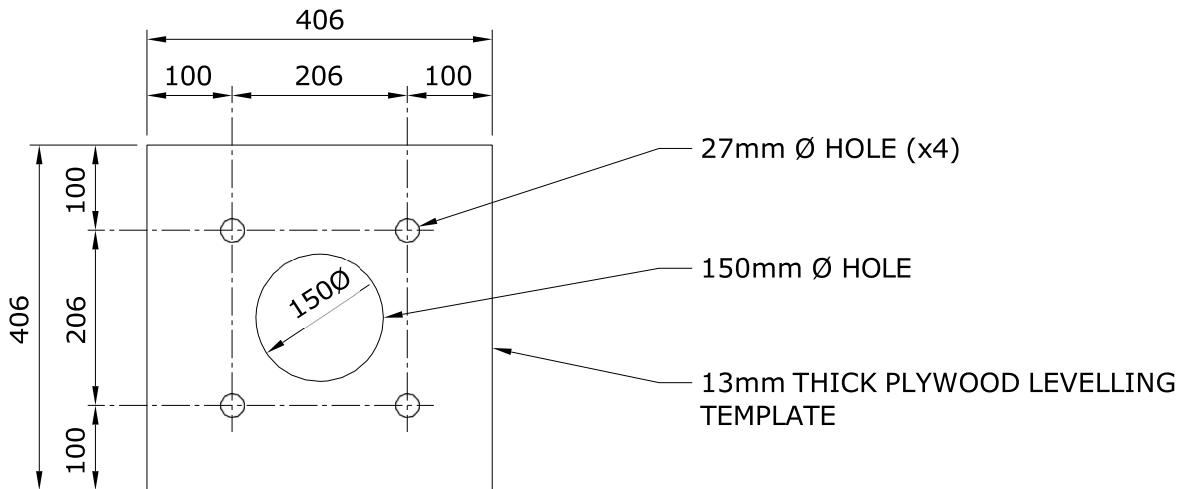

LEVELLING TEMPLATE

| | | | | | |
|--|--------------|------------|------------------|--|--------|
| APPROVED | | REVISIONS | | MANITOBA HYDRO DISTRIBUTION STANDARDS | |
| ORIGINAL DRAWING SEALED BY D.R. ORR 13-02-13 | | | | INSTALLATION OF ALUMINUM STREET LIGHT STANDARDS ON BRIDGES AND DIVIDER STRIPS | |
| DRAWN C.A. | CHECKED L.D. | DATE 13-01 | CD 300-11 | | |
| | | | SHT 0001 of 2 | | REV 00 |

ALUMINUM STREET LIGHT STANDARD MOUNTING INSTRUCTIONS

1. ENSURE MOUNTING STUDS ARE COATED WITH WHITE LITHIUM GREASE AND ARE FREE OF DIRT AND OTHER CONTAMINANTS.
2. INSTALL LEVELLING NUTS AND WASHERS. ENSURE THEY ARE LEVEL IN ALL DIRECTIONS BY USING THE LEVELLING TEMPLATE AND A CARPENTER'S LEVEL. FAILURE TO ENSURE LEVEL MOUNTING SURFACE MAY RESULT IN A CRACKED ANCHOR BASE UPON FASTENING CONNECTION WITH AN IMPACT GUN.
3. POSITION ALUMINUM STREET LIGHT STANDARD ONTO LEVELLING WASHERS AND NUTS.
4. INSTALL RETAINING WASHERS AND NUTS TO A SNUG FIT (A FEW IMPACTS WITH IMPACT GUN).
5. SNUG TIGHTENING IS TO PROGRESS SYSTEMATICALLY AND THEN RE-TIGHTENING IN THE SAME SYSTEMATIC MANNER UNTIL THE CONNECTION IS FULLY COMPACTED.
6. TIGHTEN NUTS SYSTEMATICALLY BY 2/3 OF AN ADDITIONAL TURN. SEE CD300-9 FOR ANCHOR ROD TIGHTENING METHOD.

NOTES:

1. STUD SHOULD NOT TURN IN FERRULE WHILE TIGHTENING.
2. SQUARE HEAD STUD TO PROTRUDE APPROXIMATELY ONE NUT THICKNESS BEYOND RETAINING NUT.
3. WHERE THE REMOVAL OF THE STUDS FOR REPAIR OR REPLACEMENT IS REQUIRED, THE FERRULES AND THE STUDS SHALL BE CLEANED TO REMOVE THE OLD THREAD LOCKING COMPOUND. NEW THREAD LOCKING COMPOUND (LOCKTITE 262) SHALL BE APPLIED TO THE INSERTION LENGTH OF THE STUDS PRIOR TO TIGHTENING TO FULL DEPTH.

| | | | | | | |
|--|---------|-----------|------------------|--|-----------|-----|
| APPROVED | | REVISIONS | | MANITOBA HYDRO DISTRIBUTION STANDARDS | | |
| ORIGINAL DRAWING SEALED BY D.R. ORR 13-02-13 | | | | INSTALLATION OF ALUMINUM STREET LIGHT STANDARDS ON BRIDGES AND DIVIDER STRIPS | | |
| DRAWN | CHECKED | DATE | CD 300-11 | | SHT | REV |
| C.A. | L.D. | 13-01 | | | 0002 of 2 | 00 |

STREET LIGHT POLES *

| POLE TYPE | MOUNTING HEIGHT m (ft) | MATERIAL | WEIGHT *, ** kg (±10%) |
|----------------|---------------------------|----------|---------------------------|
| STRAIGHT SHAFT | 10.7 (35) | ALUMINUM | 91 |
| DAVIT (DB) | 11.3 (37) | CONCRETE | 998 |
| DAVIT (DB) | 13.7 (45) | CONCRETE | 1087 |
| POST TOP (DB) | 6.1 (20) | CONCRETE | 544 |
| DAVIT | 7.7 (25) | STEEL | 97 |
| DAVIT | 9.1 (30) | STEEL | 125 |
| DAVIT | 10.7 (35) | STEEL | 157 |
| DAVIT | 13.7 (45) | STEEL | 219 |
| DAVIT | 16.8 (55) | STEEL | 330 |
| DAVIT | 19.8 (65) | STEEL | 428 |
| POST TOP | 4.7 (15) | STEEL | 53 |
| POST TOP | 6.1 (20) | STEEL | 68 |
| STRAIGHT SHAFT | 7.7 (25) | STEEL | 90 |
| STRAIGHT SHAFT | 9.1 (30) | STEEL | 113 |
| STRAIGHT SHAFT | 10.7 (35) | STEEL | 172 |
| STRAIGHT SHAFT | 13.7 (45) | STEEL | 220 |
| STRAIGHT SHAFT | 16.8 (55) | STEEL | 388 |
| STRAIGHT SHAFT | 19.8 (65) | STEEL | 557 |
| HI-MAST | 30.5 (100) | STEEL | 3300 |

* ALL POLES ARE BASE MOUNTED EXCEPT CONCRETE.

** WEIGHTS DO NOT INCLUDE ARMS OR LUMINAIRES.

*** WEIGHTS GATHERED FROM MANUFACTURER'S DRAWING.

| BASES | |
|-------|------------------|
| TYPE | WEIGHT kg (±10%) |
| 179 | 605 |
| 197 | 605 |
| 206 | 605 |
| 243 | 970 |
| 418 | 2151 |

| | | | | |
|--|---|---------------------------------------|--------------------------------|-----------|
| APPROVED | REVISIONS | MANITOBA HYDRO DISTRIBUTION STANDARDS | | |
| ORIGINAL DRAWING SEALED BY D.R. ORR 16-01-14 | 21-07 | 2 | ADDED HI-MAST POLE TO TABLE | |
| | 18-04 | 1 | UPDATED TABLES | |
| | RIGGING WEIGHTS OF STREET LIGHT COMPONENTS | | | |
| DRAWN C.A. | CHECKED J.R. | DATE 16-01 | CD 300-18 | |
| | | | SHT 0001 of 1 | REV 02 |

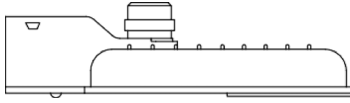

LED ROADWAY LUMINAIRE

* THESE LUMINAIRES PROVIDE A VERY WIDE BEAM PATTERN (IES TYPE IV). CAREFUL CONSIDERATION OF LIGHT TRESPASS MUST BE GIVEN WHEN INSTALLING NEAR RESIDENTIAL HOUSING. IN THESE CASES, CONSIDER USING THE 500W.

| LED ROADWAY LUMINAIRES | | | |
|-----------------------------|----------------|----------|----------|
| LUMINAIRE WATTAGE (NOMINAL) | REPLACES (HPS) | CIIC | |
| | | GREY | BLACK |
| 40 W LED | 70 W HPS | 05 15 44 | 05 15 71 |
| 60 W LED | 100 W HPS | 05 15 45 | 05 15 73 |
| 90 W LED | 150 W HPS | 05 15 47 | 05 15 74 |
| 150 W LED | 250 W HPS | 05 15 48 | 05 15 75 |
| 240 W LED | 400 W HPS | 05 15 49 | 05 15 76 |
| 500 W LED | 1000 W HPS | 06 55 67 | |
| 600 W LED * | 1000 W HPS | 06 55 66 | |

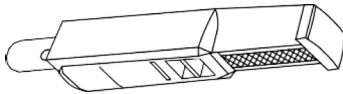

LED LANE LUMINAIRE

- LED LANE LUMINAIRES ARE AVAILABLE WITH GREY COATING ONLY.

| LED LANE LUMINAIRES | | |
|-----------------------------|----------------|----------|
| LUMINAIRE WATTAGE (NOMINAL) | REPLACES (HPS) | CIIC |
| 50 W LED | 70 W HPS | 05 15 50 |

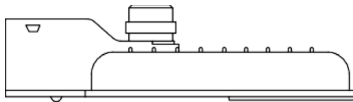

LED DUSK-TO-DAWN LUMINAIRE

- LED DUSK-TO-DAWN LUMINAIRES ARE AVAILABLE WITH GREY COATING ONLY.

| LED DUSK-TO-DAWN (AREA) LUMINAIRES | | |
|------------------------------------|----------------|----------|
| LUMINAIRE WATTAGE (NOMINAL) | REPLACES (HPS) | CIIC |
| 60 W LED | 100 W HPS | 05 15 51 |
| 90 W LED | 150 W HPS | 05 15 52 |

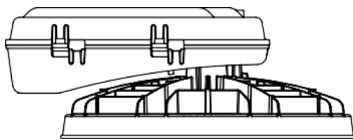

LED HI-MAST LUMINAIRE

- THERE HAVE BEEN OCCASIONS WHERE A 1000W HPS LUMINAIRE WAS USED TO REPLACE A 400W HPS HI-MAST LUMINAIRE. IN THESE CASES, REPLACE THEM WITH THE 300W LED HI-MAST LUMINAIRE.
- ALL LED LUMINAIRES AUTOMATICALLY ADJUST FOR EITHER A 120V OR 240V SUPPLY.
- ALL LED LUMINAIRES COME WITH A PHOTOCCELL RECEPTACLE.

| LED HI-MAST LUMINAIRES | | |
|-----------------------------|----------------|----------|
| LUMINAIRE WATTAGE (NOMINAL) | REPLACES (HPS) | CIIC |
| 300 W LED | 400 W HPS | 06 34 98 |

| | | | | | |
|--|--------------|------------|---------------------------------------|--------|---|
| APPROVED | REVISIONS | | MANITOBA HYDRO DISTRIBUTION STANDARDS | | |
| ORIGINAL DRAWING SEALED BY D.R. ORR 15-02-11 | | | STANDARD LED LUMINAIRES | | |
| | 21-07 | 2 | | | ADDED 500W & 600W ROADWAY AND 300W HI-MAST LUMINAIRES |
| | 16-12 | 1 | | | REVISED NOTES |
| DRAWN C.A. | CHECKED J.R. | DATE 15-02 | CD 300-24 | | |
| | | | SHT 0001 of 2 | REV 02 | |

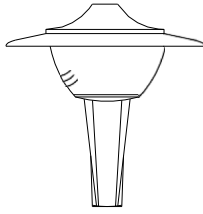

**LED POST TOP LUMINAIRE
- CONTEMPORARY**

| LED POST TOP LUMINAIRES - CONTEMPORARY | | |
|--|----------|--------------------------|
| LUMINAIRE WATTAGE (NOMINAL) | CIIC | PHOTOMETRIC DISTRIBUTION |
| 60 W LED | 05 17 30 | ASYMMETRICAL |

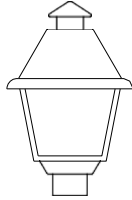

**LED POST TOP LUMINAIRE
- COLONIAL**

| LED POST TOP LUMINAIRES - COLONIAL | | |
|------------------------------------|----------|--------------------------|
| LUMINAIRE WATTAGE (NOMINAL) | CIIC | PHOTOMETRIC DISTRIBUTION |
| 60 W LED | 05 17 28 | ASYMMETRICAL |
| 60 W LED | 05 17 29 | SYMMETRICAL |



**LED POST TOP LUMINAIRE
- ACORN**

| LED POST TOP LUMINAIRES - ACORN | | |
|---------------------------------|----------|--------------------------|
| LUMINAIRE WATTAGE (NOMINAL) | CIIC | PHOTOMETRIC DISTRIBUTION |
| 60 W LED | 05 17 26 | ASYMMETRICAL |
| 60 W LED | 05 17 27 | SYMMETRICAL |



**LED POST TOP LUMINAIRE
- OCTAGONAL LANTERN**

| LED POST TOP LUMINAIRES - OCTAGONAL LANTERN | | |
|---|----------|--------------------------|
| LUMINAIRE WATTAGE (NOMINAL) | CIIC | PHOTOMETRIC DISTRIBUTION |
| 60 W LED | 05 17 32 | ASYMMETRICAL |
| 60 W LED | 05 17 33 | SYMMETRICAL |

- LED CONTEMPORARY LUMINAIRES ARE AVAILABLE WITH GREY COATING ONLY. ALL OTHER DECORATIVE LUMINAIRES ARE BLACK.
- ALL LED LUMINAIRES AUTOMATICALLY ADJUST FOR EITHER A 120V OR 240V SUPPLY.
- ALL LED LUMINAIRES COME WITH A PHOTOCCELL RECEPTACLE.

| | | | | |
|--|--------------------------------|---------------|---------------------------------------|-----------|
| APPROVED | REVISIONS | | MANITOBA HYDRO DISTRIBUTION STANDARDS | |
| ORIGINAL DRAWING SEALED BY D.R. ORR 15-02-11 | 21-07 | 2 | CORRECTED TYPO | |
| | 16-12 | 1 | REVISED NOTES | |
| | STANDARD LED LUMINAIRES | | | |
| DRAWN C.A. | CHECKED J.R. | DATE 15-02 | CD 300-24 | |
| | | | SHT 0002 of 2 | REV 02 |

TRENCH AND PLOW-IN LOCATION

GENERALLY, THE TRENCH LOCATION WILL DICTATE THE LOCATION OF THE LIGHT STANDARDS. CONTACT SHALL BE MADE WITH THE GOVERNING MUNICIPAL AUTHORITY TO DETERMINE THEIR SET BACK REQUIREMENTS. CONTACT SHALL ALSO BE MADE WITH THE CITY OF WINNIPEG UNDERGROUND STRUCTURES OR THE INDIVIDUAL UTILITIES OUTSIDE WINNIPEG TO DETERMINE THE EXISTENCE AND EXACT LOCATION OF OTHER UTILITIES PLANT. THIS INFORMATION WILL BE INCLUDED ON THE WORK ORDER PLANS.

DEPTH OF BURIAL

THE CABLE SHALL BE BURIED BELOW THE SURFACE OF THE EARTH A MINIMUM OF 600mm IN SODDED AREAS AND 1000mm IN ROADWAYS.

TRENCH DETAILS

TYPICAL TRENCH DETAILS FOR SODDED AREAS ARE SHOWN BELOW, FOR TRENCH DETAILS UNDER ROADWAYS REFER TO DRAWING CD205-14. SEE NOTES ON SHEET 2 of 2.

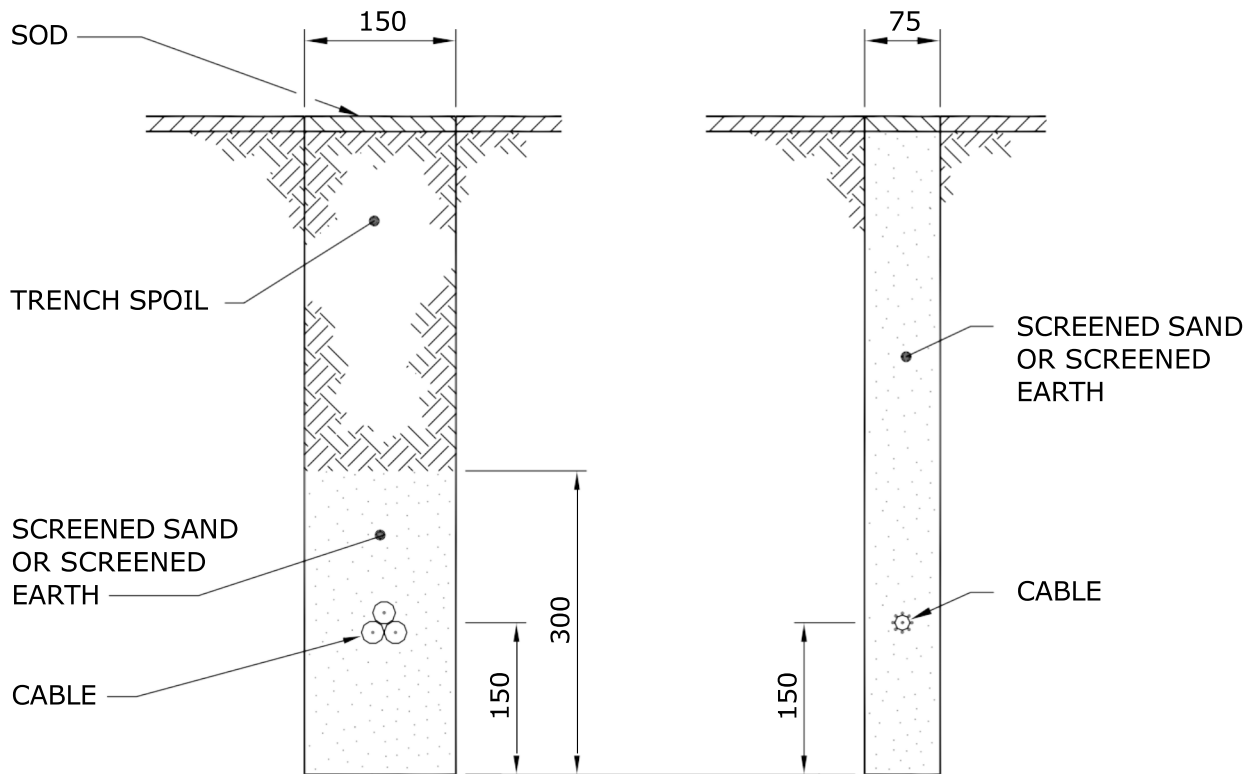

NOTE: DIMENSIONS SHOWN ARE MILLIMETRES.

| | | | | | |
|--|---------|---------------|-------------------------------|--|------------------|
| APPROVED | | REVISIONS | | MANITOBA HYDRO DISTRIBUTION STANDARDS | |
| ORIGINAL DRAWING SEALED BY E.H. WIEBE 89-04-28 | 96-01 | 3 | ROADWAY DEPTH ADDED | PLOWING AND TRENCHING DETAILS FOR UNDERGROUND STREET LIGHT CIRCUITS | |
| | 95-09 | 2 | BURIAL DEPTH NOTE ADDED | | |
| | 94-04 | 1 | COMBINED WITH DWG. CD305-2 | | |
| DRAWN W.B./CAD | CHECKED | DATE 88-07 | CD 305-1 | | SHT 0001 OF 2 |
| | | | | | REV 03 |

NOTES:

1. FOR TYPICAL TRENCH DETAIL INSTALLATION UNDER ROADWAYS, REFER TO DRAWING CD205-14.
2. THESE ARE ALTERNATIVE TRENCH WIDTHS. A 75mm TRENCH IS PREFERABLE WHERE THE GROUND IS FIRM AND A CLEAN CUT CAN BE MADE. A 150mm TRENCH IS PREFERABLE WHERE THE GROUND IS TOO LOOSE TO MAINTAIN A FIRM TRENCH WALL.
3. THE CABLES INDICATED IN THE VIEWS CAN BE USED IN EITHER TRENCH.
4. THE 75mm TRENCH SHALL BE BACKFILLED WITH SCREENED SAND OR SCREENED EARTH.
5. THE 150mm TRENCH SHALL BE BACKFILLED WITH THE TRENCH SPOIL IF IT IS FREE FROM ROCKS OR DEBRIS. IF THE TRENCH SPOIL CONTAINS ROCKS OR DEBRIS, SCREENED SAND OR SCREENED EARTH SHALL BE INSTALLED AS SHOWN.

| | | | | | | |
|--|---------|---------------|-----------------|--|------------------|-------------------------------|
| APPROVED | | REVISIONS | | MANITOBA HYDRO DISTRIBUTION STANDARDS | | |
| ORIGINAL DRAWING SEALED BY E.H. WIEBE 89-04-28 | | | | PLOWING AND TRENCHING DETAILS FOR UNDERGROUND STREET LIGHT CIRCUITS | | |
| | | 96-01 | 2 | | | NOTES REVISED |
| | | 94-04 | 1 | | | COMBINED WITH DWG. CD305-2 |
| DRAWN W.B./CAD | CHECKED | DATE 88-07 | CD 305-1 | | SHT 0002 of 2 | |
| | | | | | REV 02 | |

1. **GENERAL**

PLOWED-IN CABLES SHALL BE PULLED TO 1m ABOVE GRADE AT EACH STREET LIGHT STANDARD LOCATION. THE CABLE DEPTH SHALL BE MAINTAINED AT THE 600mm PLOW DEPTH AS CLOSE AS POSSIBLE TO THE STREET LIGHT STANDARD LOCATION BEFORE RAISING THE PLOW. THE PLOW SHALL BE RETURNED TO THE 600mm PLOW DEPTH AS CLOSE AS POSSIBLE TO THE CENTRE LINE OF THE STREET LIGHT STANDARD LOCATION.

CABLES LAID IN TRENCHES SHALL HAVE SUFFICIENT SLACK TO ALLOW FOR FUTURE MOVEMENT OR SETTLING OF THE TRENCH FLOOR. CABLES SHALL PROJECT 1m ABOVE GRADE AT EACH LOCATION.

2. **USE OF POLYETHYLENE PIPE**

2.1 WHERE CABLES ARE INSTALLED UNDER EXISTING PAVEMENT, POLYETHYLENE PIPE SHALL BE INSTALLED TO PROTECT THE CABLES IF THE HOLE IS AUGERED OR PUSHED THROUGH MATERIAL CONTAINING ROCKS, STONES, OR DEBRIS.

2.2 AT THE JUNCTION OF THE MAIN TRENCH AND THE STREET OR DRIVEWAY CROSSING, THE BOTTOM OF THE TRENCH SHALL BE BACKFILLED AND TAMPED TO THE LEVEL OF THE POLYETHYLENE PIPES TO PREVENT SHARP BENDS IN THE CABLE AND TRAPPING OF WATER IN THE PIPE.

3. **SPLICES - UNDERGROUND CABLES**

UNDERGROUND STREET LIGHT CABLES (i.e. #4 ALUMINUM CONCENTRIC NEUTRAL CABLE AND 1/0 TRIPLEXED CABLE) ARE TO BE SPLICED USING AN APPROPRIATE COMPRESSION SLEEVE (SEE DRAWING CD210-21) AND THE SPLICE IS TO BE INSULATED USING ONE OF THE FOLLOWING METHODS:

- 1) RAYCHEM RAYVOLVE SPLICE
- 2) PRE-STRETCHED INSULATING TUBING SPLICE
- 3) HEAT SHRINK INSULATING TUBING SPLICE
- 4) TAPED SPLICE

FOR COMPLETE INSTRUCTIONS REGARDING THE ABOVE SPLICES, REFER TO DRAWING CD215-12.

| | | | | | |
|--|--|-----------------------------------|--|--|--|
| APPROVED | | REVISIONS | | MANITOBA HYDRO DISTRIBUTION STANDARDS | |
| ORIGINAL DRAWING SEALED BY E.H. WIEBE 89-04-28 | | 94-04 1 DWG. REFERENCE CHANGED | | INSTALLATION OF STREET LIGHT CABLES | |
| | | | | | |
| | | DATE 88-07 | | CD 310-1 | |
| | | | | | |

4. **CABLE END CAPS**

STREET LIGHT CABLES WHICH ARE NOT GOING TO BE SPLICED OR TERMINATED IMMEDIATELY FOLLOWING INSTALLATION SHALL BE CUT SQUARE AND SEALED WITH AN END CAP. REFER TO DRAWING CD215-21 FOR DETAILS.

5. **GROUNDING OF STREET LIGHT STANDARDS**

5.1 ALL STREET LIGHT STANDARDS SHALL BE GROUNDED BY CONNECTING THE NEUTRAL TO THE GROUND STUD INSIDE THE STANDARD. REFER TO DRAWING CD310-4 FOR DETAILS.

5.2 A GROUND ROD SHALL BE INSTALLED AND CONNECTED TO THE GROUND STUD AT THE LAST STANDARD ON JACKETED STREET LIGHT CIRCUITS.

5.3 A GROUND ROD SHALL BE INSTALLED AND CONNECTED TO THE GROUND STUD AT EVERY THIRD STANDARD AND AT THE LAST STANDARD ON C/N STREET LIGHT CIRCUITS.

SUPERCEDES ORIGINAL SEALED BY E. WIEBE ON 89-04-28

| | | | | | | |
|---|-----------------|---------------|-----------------|--|------------------|-------------------------------------|
| APPROVED | | REVISIONS | | MANITOBA HYDRO DISTRIBUTION STANDARDS | | |
| ORIGINAL DRAWING SEALED BY P.S.C. LOEWEN 22-09-23 | | | | INSTALLATION OF STREET LIGHT CABLES | | |
| | | 22-09 | 2 | | | ADDED NOTE 5.3, REVISED NOTE 5.2 |
| | | 94-04 | 1 | | | DWG. REFERENCE CHANGED |
| DRAWN C.A. | CHECKED L.D. | DATE 22-09 | CD 310-1 | | SHT 0002 of 2 | |
| | | | | | REV 02 | |

RAYCHEM GELCAP CIIC# 04-29-36

GENERAL INSTRUCTIONS:

1. REMOVE 16mm (5/8") OF INSULATION AND CLEAN EXPOSED ENDS.

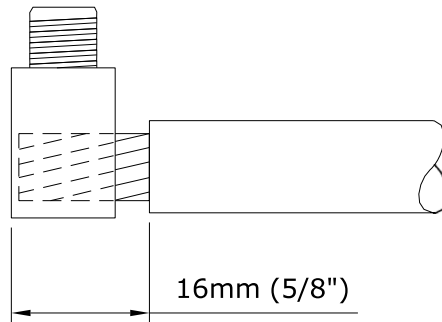

2. INSERT CONDUCTORS INTO CORRECT HOLES AND TORQUE AS SHOWN:

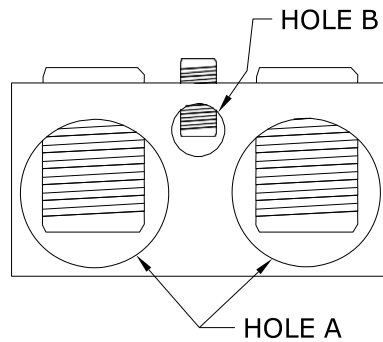

| HOLE A | | HOLE B | |
|---|-----------------------------------|--------------------------|-----------------------------------|
| WIRE RANGE | RECOMMENDED TORQUE VALUES | WIRE RANGE | RECOMMENDED TORQUE VALUES |
| #14 - 2/0 • STREET LIGHT CIRCUIT CABLES • GROUNDING CONNECTIONS • CONCENTRIC NEUTRAL • FUSE HOLDER WIRE | 14 - 20 N-m (120 - 180 in-lbs) | #14 - #6 • LAMP LEADS | 14 - 17 N-m (120 - 150 in-lbs) |

| | | | | | |
|--|-----------|-------|---------------------------------------|-----------|-----|
| APPROVED | REVISIONS | | MANITOBA HYDRO DISTRIBUTION STANDARDS | | |
| ORIGINAL DRAWING SEALED BY J.J.D. RINGASH 18-03-05 | | | RAYCHEM GELCAP SPLICE | | |
| DRAWN | CHECKED | DATE | CD 310-3 | SHT | REV |
| C.A. | L.D. | 17-11 | | 0001 of 3 | 00 |

- INSTALL CLAMP ON CAP. ENSURE THE TWO PINS ON THE BOTTOM EDGE OF THE CLAMP MATE WITH THE HOLES OF THE CAP AS SHOWN IN FIGURE 1a BELOW.

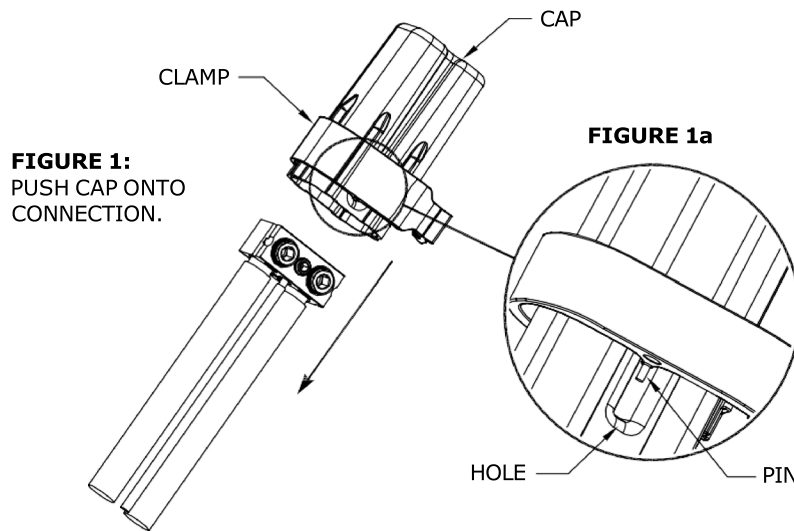

- INSTALL CAP BY HOLDING ALL WIRES AND PUSHING THE CAP OVER THE CONNECTION ASSEMBLY UNTIL IT GOES NO FURTHER AS SHOWN IN FIGURE 1 ABOVE.
- SNAP CLAMP CLOSED. IF NECESSARY, USE PLIERS TO SNAP CLAMP CLOSED AS SHOWN IN FIGURE 2 BELOW.

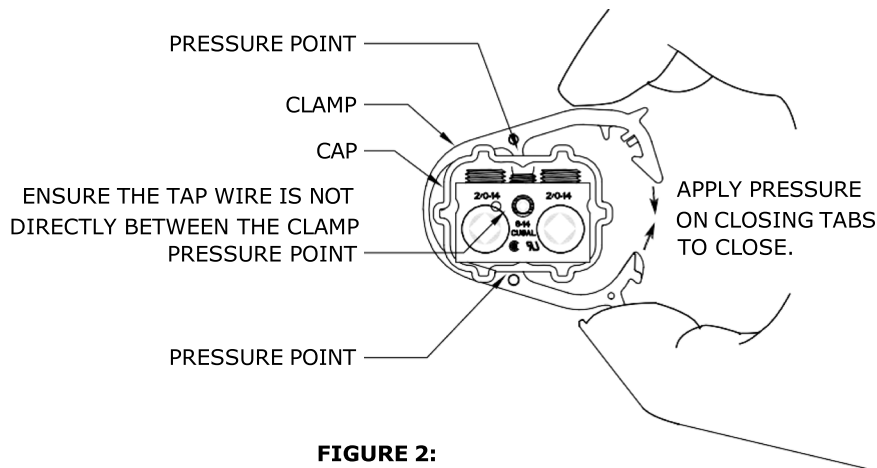
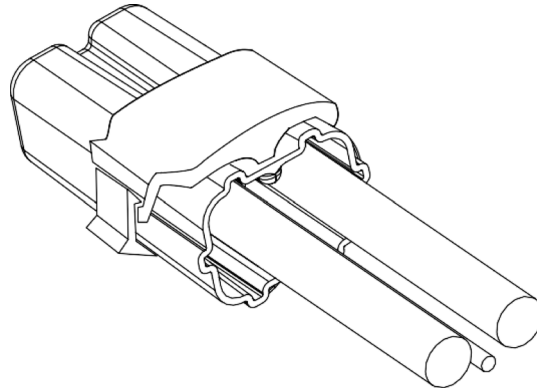

FIGURE 2:
CLAMP PRESSURE POINTS SHOULD FIT INTO OPPOSING GROOVES OF CAP AND APPLY PRESSURE BETWEEN CABLES. SNAP CLAMP CLOSED.

| | | | | | | | | |
|--|-----------------|---------------|---------------------------------------|--|-----|-----|-----------|----|
| APPROVED | REVISIONS | | MANITOBA HYDRO DISTRIBUTION STANDARDS | | | | | |
| ORIGINAL DRAWING SEALED BY J.J.D. RINGASH 18-03-05 | | | RAYCHEM GELCAP SPLICE | | | | | |
| DRAWN C.A. | CHECKED L.D. | DATE 17-11 | CD 310-3 | <table border="1"> <tr> <td>SHT</td> <td>REV</td> </tr> <tr> <td>0002 of 3</td> <td>00</td> </tr> </table> | SHT | REV | 0002 of 3 | 00 |
| SHT | REV | | | | | | | |
| 0002 of 3 | 00 | | | | | | | |

6. INSPECT THE INSTALLATION BY GENTLY PULLING ON THE CAP ENSURING IT IS LOCKED IN PLACE AND COVERS CONNECTOR AND BARE CONDUCTOR. THERE SHOULD BE NO EXPOSED METAL. ENSURE TAP CABLE IS NOT CAUGHT BETWEEN PRESSURE POINTS OF CLAMP. INSTALLATION IS COMPLETE.



7. TO REMOVE, INSERT SCREWDRIVER BETWEEN THE CLOSING TABS AND TWIST TO OPEN THE CLAMP. REMOVE CAP SLOWLY FROM CONNECTION ALLOWING GEL TO REMAIN IN CAP.

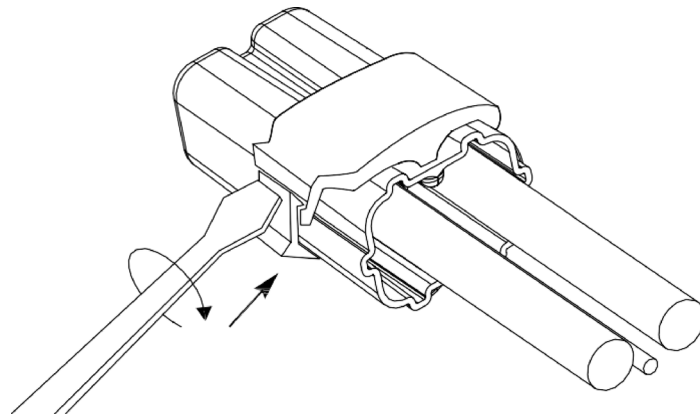

| | | | | | | | | | |
|--|-----------------|---------------|-----------------|---------------------------------------|--|-----|-----|-----------|----|
| APPROVED | | REVISIONS | | MANITOBA HYDRO DISTRIBUTION STANDARDS | | | | | |
| ORIGINAL DRAWING SEALED BY J.J.D. RINGASH 18-03-05 | | | | RAYCHEM GELCAP SPLICE | | | | | |
| DRAWN C.A. | CHECKED L.D. | DATE 17-11 | CD 310-3 | | <table border="1"> <tr> <td>SHT</td> <td>REV</td> </tr> <tr> <td>0003 of 3</td> <td>00</td> </tr> </table> | SHT | REV | 0003 of 3 | 00 |
| SHT | REV | | | | | | | | |
| 0003 of 3 | 00 | | | | | | | | |

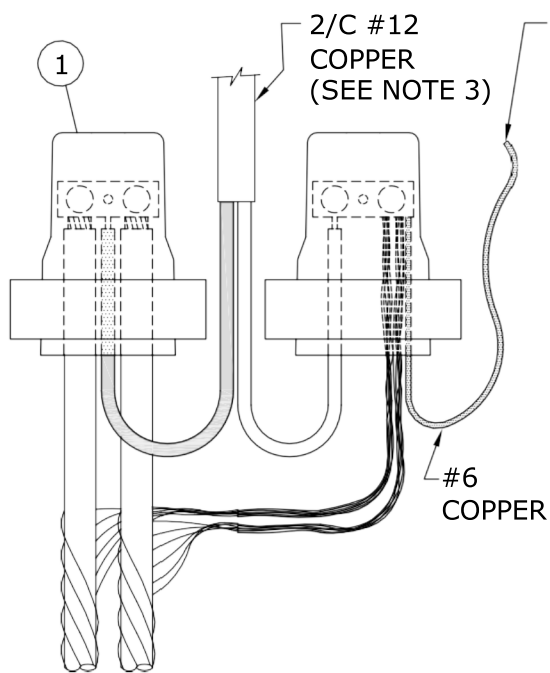

**No. 4 ALUMINUM C/N CABLE
(TYPICAL FEED THROUGH)**

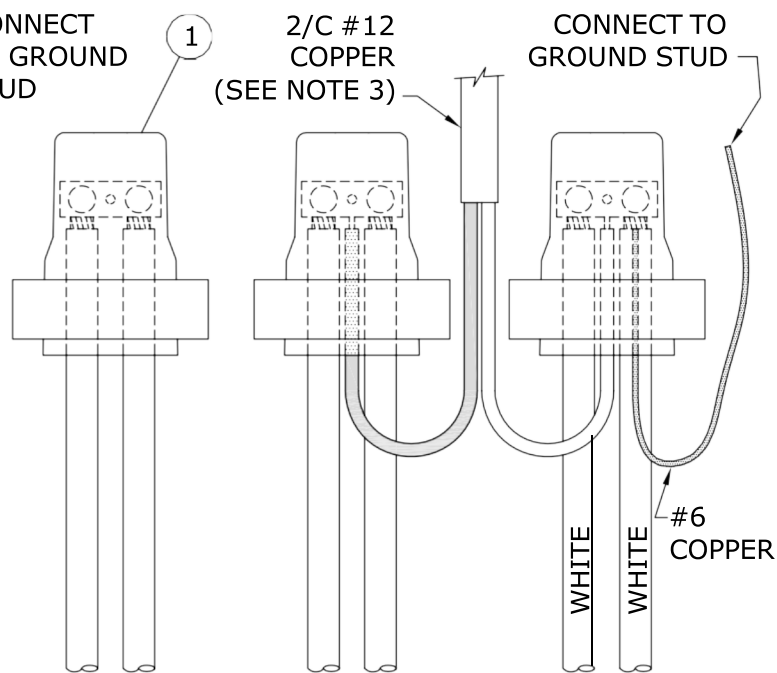

**1/0 ALUMINUM TRIPLEX CABLE
(TYPICAL FEED THROUGH)**

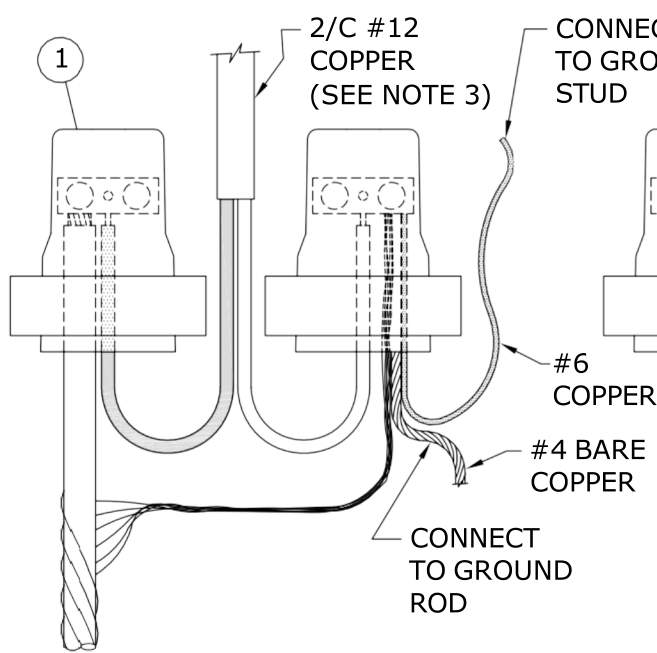

**No. 4 ALUMINUM C/N CABLE
(TYPICAL END OF CIRCUIT)**

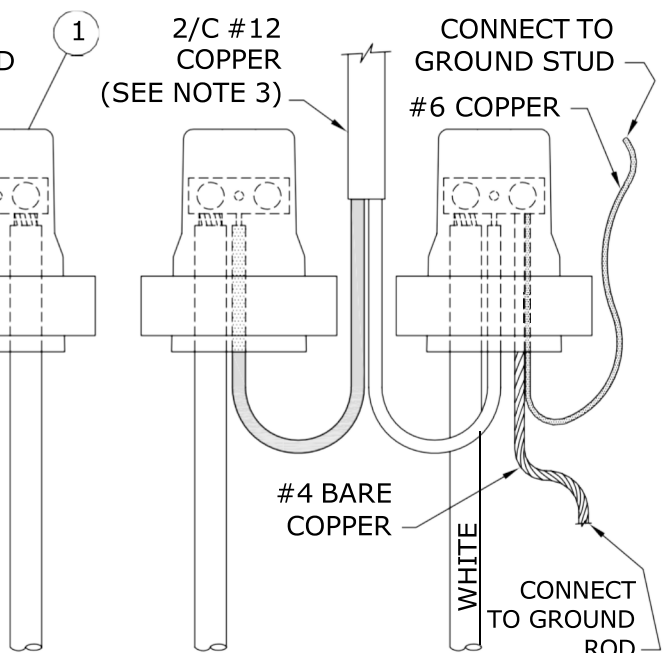

**1/0 ALUMINUM TRIPLEX CABLE
(TYPICAL END OF CIRCUIT)**

SUPERCEDES ORIGINAL SEALED BY E. WIEBE ON 89-04-28

| | | | | |
|--|----------------------|---------------|---|--|
| APPROVED | REVISIONS | | MANITOBA HYDRO DISTRIBUTION STANDARDS | |
| ORIGINAL DRAWING SEALED BY J.J.D. RINGASH 18-05-11 | 22-09 | 4 | ADDED CONNECTION TO GROUND STUD FOR C/N CABLE | |
| | 21-06 | 3 | ADDED NOTE FOR DUAL LUMINAIRE SUPPLY | |
| | | | | |
| DRAWN C.A. | CHECKED L.D./P.L. | DATE 18-04 | CD 310-4 | |
| | | | | |

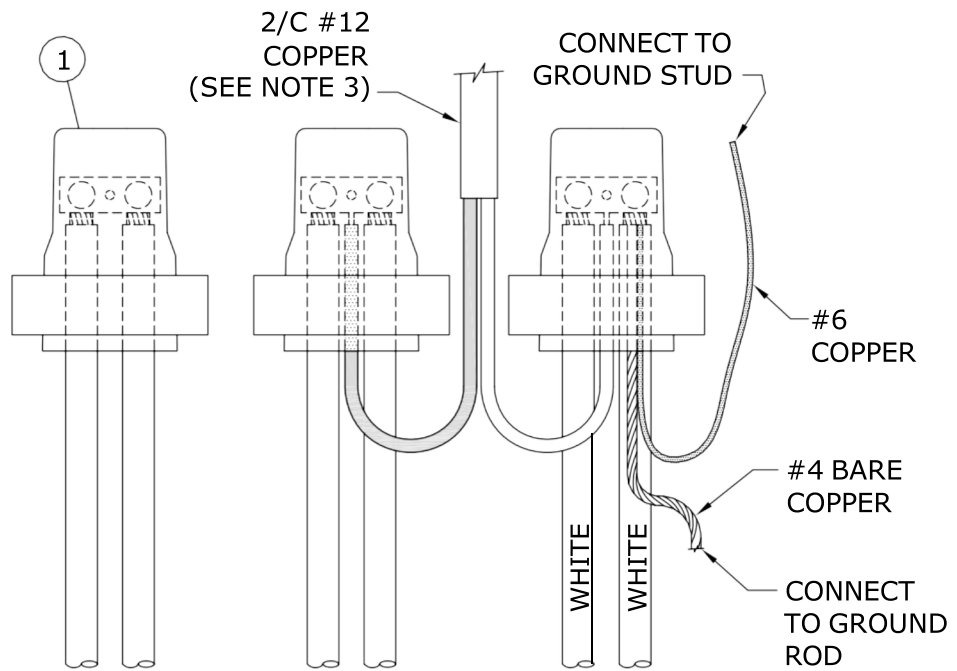

**1/0 ALUMINUM TRIPLEX CABLE
(TYPICAL EVERY THIRD STANDARD)**

BILL OF MATERIAL

| ITEM No. | DESCRIPTION | STORES CODE No. | |
|----------|-------------|--------------------------|------------------------------|
| | | FOR USE WITH #4 AL. C/N | FOR USE WITH 1/0 AL. TRIPLEX |
| 1 | GEL CAP | 04-29-36 (2 REQUIRED) | 04-29-36 (3 REQUIRED) |

NOTES:

- 1. LEAVE SUFFICIENT SLACK ON CONDUCTORS TO ALLOW REMOVAL FROM HANDHOLE FOR MAINTENANCE.**
- REFER TO DRAWING CD310-3 FOR GEL CAP INSTALLATION INSTRUCTIONS.
- INSTALL PARALLEL 2/C #12 COPPER FOR DOUBLE LUMINAIRE STANDARDS. TIE TOGETHER IN HANDHOLE.

SUPERCEDES ORIGINAL SEALED BY E. WIEBE ON 94-07-03

| | | | | |
|--|-------------------|------------|--|--|
| APPROVED | REVISIONS | | MANITOBA HYDRO DISTRIBUTION STANDARDS | |
| ORIGINAL DRAWING SEALED BY J.J.D. RINGASH 18-05-11 | 22-09 | 2 | ADDED DETAIL FOR EVERY THIRD STREET LIGHT STANDARD | |
| | 18-04 | 1 | ADDED SHT 3 & 4, MOVED PREVIOUS INFO FROM SHT2 TO SHT4. ADDED NEW BOM WITH GELCAP, REVISED TITLE, RESEALED | |
| DRAWN C.A. | CHECKED L.D./P.L. | DATE 18-04 | CD 310-4 | |
| | | | | |

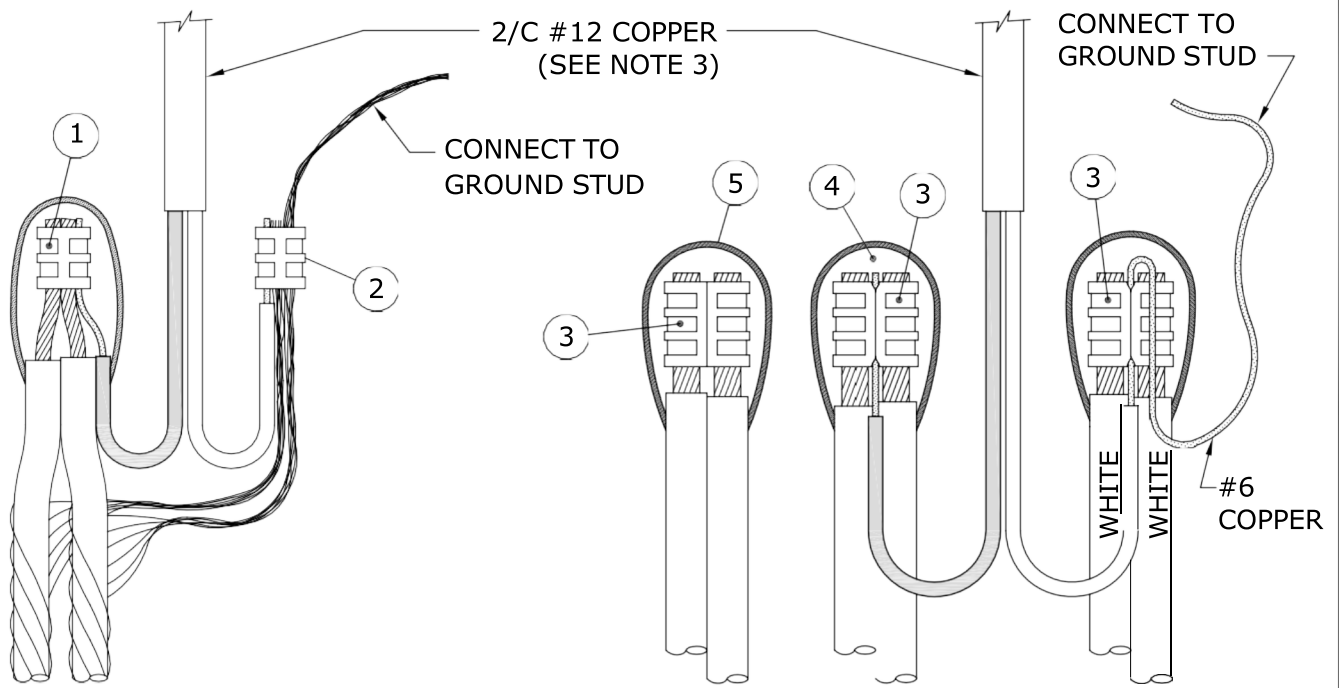

**No. 4 ALUMINUM C/N CABLE
(TYPICAL FEED THROUGH)**

**1/0 ALUMINUM TRIPLEX CABLE
(TYPICAL FEED THROUGH)**

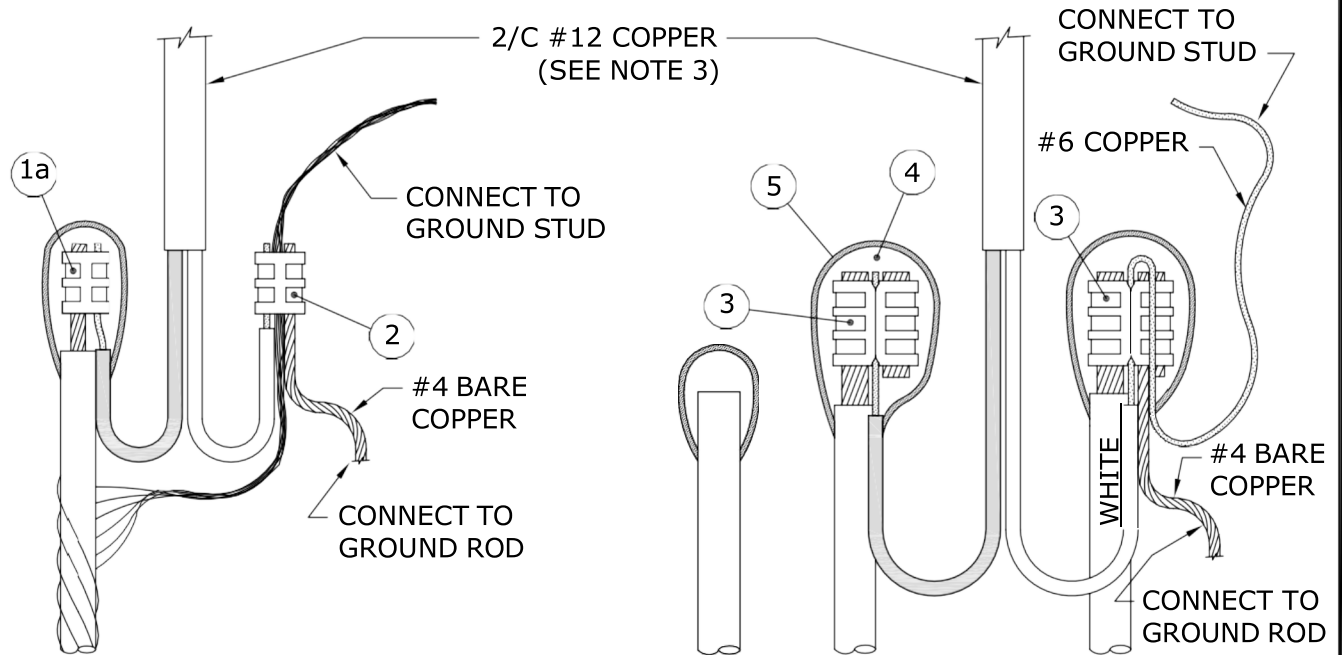

**No. 4 ALUMINUM C/N CABLE
(TYPICAL END OF CIRCUIT)**

**1/0 ALUMINUM TRIPLEX CABLE
(TYPICAL END OF CIRCUIT)**

| | | | | |
|--|----------------------|---------------|--|---|
| APPROVED | REVISIONS | | MANITOBA HYDRO DISTRIBUTION STANDARDS | |
| ORIGINAL DRAWING SEALED BY J.J.D. RINGASH 18-05-11 | 22-09 | 2 | ADDED COPPER LABEL FOR #4 BARE & #6 | CONNECTION DETAIL IN STREET LIGHT STANDARD |
| | 21-06 | 1 | ADDED NOTE FOR DUAL LUMINAIRE SUPPLY | |
| | 18-04 | 0 | MOVED FROM SHEET 1 | |
| DRAWN C.A. | CHECKED L.D./P.L. | DATE 18-04 | CD 310-4 | |
| | | | SHT 0003 of 4 | REV 02 |

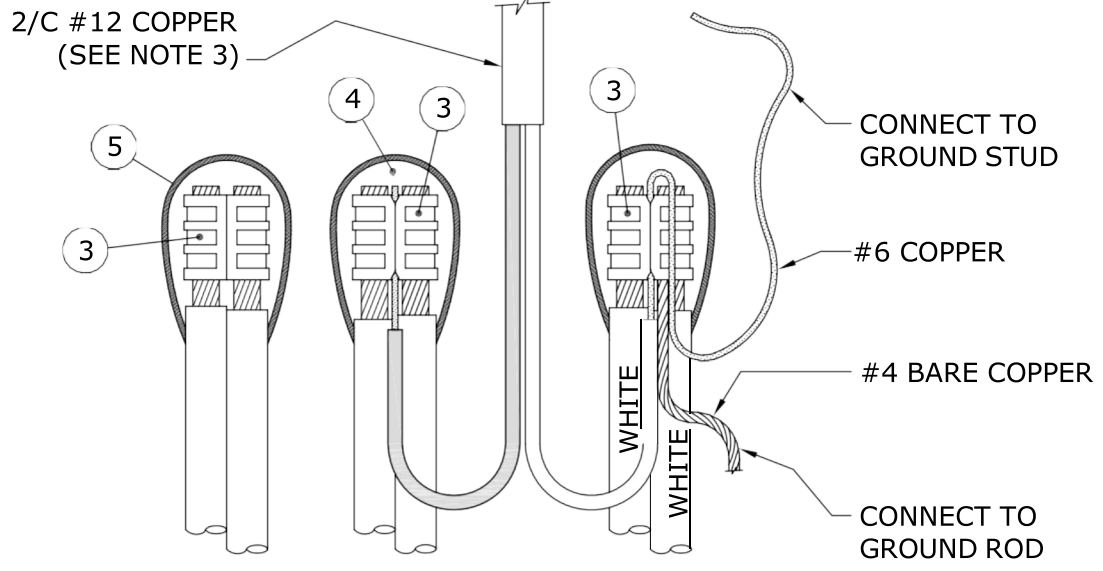

**1/0 ALUMINUM TRIPLEX CABLE
(TYPICAL EVERY THIRD STANDARD)**

BILL OF MATERIAL

| ITEM No. | DESCRIPTION | STORES CODE No. | | QUANTITY |
|----------|------------------------------|-------------------------|------------------------------|----------|
| | | FOR USE WITH #4 AL. C/N | FOR USE WITH 1/0 AL. TRIPLEX | |
| 1 | 'C' TYPE AL. COMPRESSION TAP | 74-41-30 | --- | 1 |
| 1a | 'H' TYPE AL. COMPRESSION TAP | 74-40-10 | --- | 1 * |
| 2 | 'C' TYPE CU. COMPRESSION TAP | 74-40-90 | --- | 1 |
| 3 | 'H' TYPE AL. COMPRESSION TAP | --- | 74-40-60 | 3 ** |
| 4 | TAPE, SELF-AMALGAMATING EPR | 78-55-23 | 78-55-23 | 1/4 ROLL |
| 5 | TAPE, COLD WEATHER VINYL | 78-55-98 | 78-55-98 | 1/4 ROLL |

- * FOR END OF CIRCUIT WHEN USING ONLY ONE CABLE.
- ** AT END OF CIRCUIT, QUANTITY MAY BE LESS THAN SHOWN.

NOTES:

- 1. LEAVE SUFFICIENT SLACK ON CONDUCTORS TO ALLOW REMOVAL FROM HANDHOLE FOR MAINTENANCE.**
2. FOR PROPER TAPING PROCEDURE, REFER TO DRAWING CD215-12.
3. INSTALL PARALLEL 2/C #12 COPPER FOR DOUBLE LUMINAIRE STANDARDS. TIE TOGETHER IN HANDHOLE.

| | | | | |
|--|----------------------|---------------|---|-----------|
| APPROVED | REVISIONS | | MANITOBA HYDRO DISTRIBUTION STANDARDS | |
| ORIGINAL DRAWING SEALED BY J.J.D. RINGASH 18-05-11 | 22-09 | 1 | ADDED DETAIL FOR EVERY THIRD STREET LIGHT STANDARD | |
| | 18-04 | 0 | MOVED FROM SHEET 2 | |
| | | | CONNECTION DETAIL IN STREET LIGHT STANDARD | |
| DRAWN C.A. | CHECKED L.D./P.L. | DATE 18-04 | CD 310-4 | |
| | | | SHT 0004 of 4 | REV 01 |

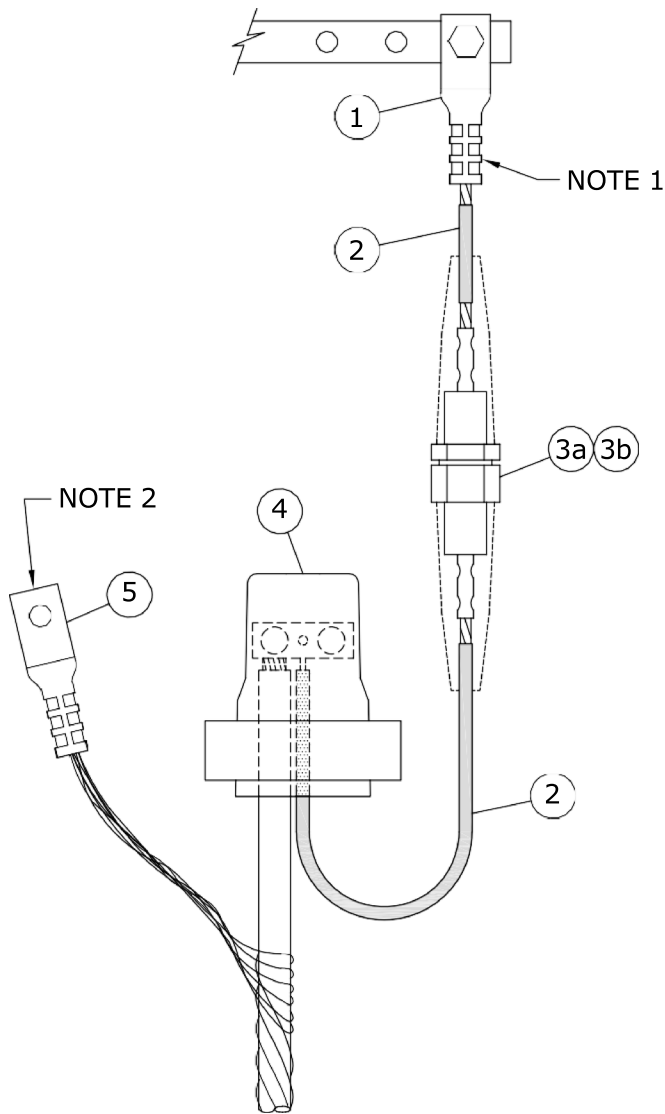

**No. 4 ALUMINUM
C/N CABLE**

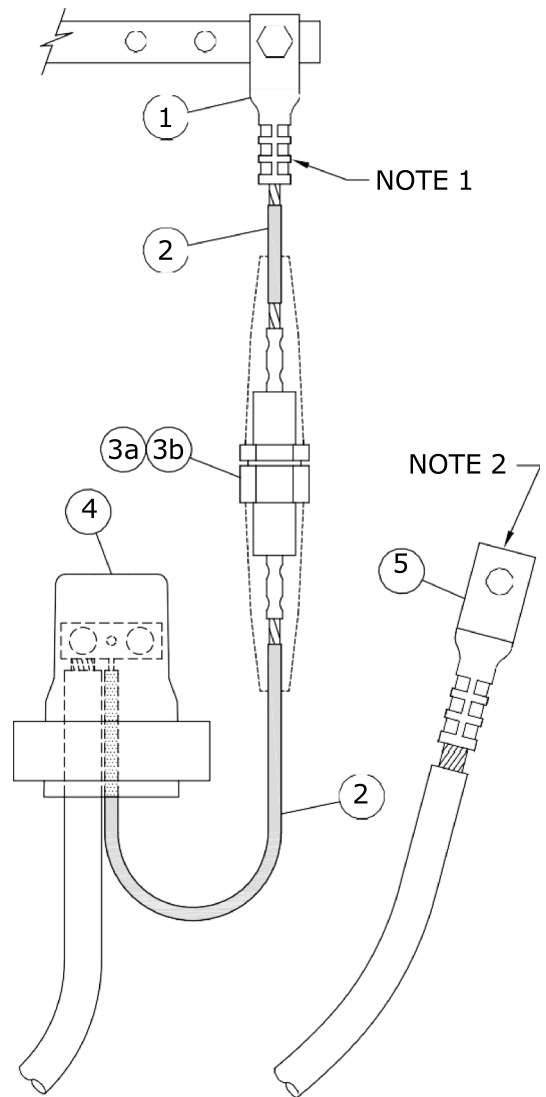

**1/0 ALUMINUM
TRIPLEX CABLE**

SUPERCEDES ORIGINAL SEALED BY E. WIEBE ON 89-04-28

| | | | | | |
|--|-----------------|---------------|---|--|--|
| APPROVED | | REVISIONS | | MANITOBA HYDRO DISTRIBUTION STANDARDS | |
| ORIGINAL DRAWING SEALED BY J.J.D. RINGASH 18-03-05 | 17-11 | 2 | ADDED SHT 3 & 4, MOVED PREVIOUS INFO FROM SHT1 TO SHT3, ADDED NEW GELCAP, DWG, RESEALED | STREET LIGHT CIRCUIT PROTECTED BY A 60A FUSE AT TRANSFORMER | |
| | 94-04 | 1 | CONN. REVISED DUE TO INSUL. NEUTRAL | | |
| DRAWN C.A. | CHECKED L.D. | DATE 17-10 | | CD 310-8 | |
| | | | | | |

BILL OF MATERIAL

| ITEM No. | DESCRIPTION | STORES CODE No. | | QUANTITY * |
|----------|----------------------------|-------------------------|------------------------------|------------|
| | | FOR USE WITH #4 AL. C/N | FOR USE WITH 1/0 AL. TRIPLEX | |
| 1 | LUG, TERMINAL, COMPRESSION | 44-66-63 | 44-66-63 | 1 |
| 2 | WIRE, #6 CU., 600V, PVC | 93-10-06 | 93-10-06 | 1m |
| 3a | FUSEHOLDER, 60A C/W BOOTS | 31-91-60 | 31-91-60 | 1 |
| 3b | FUSE, STREET LIGHT, 60A | 31-14-60 | 31-14-60 | 1 |
| 4 | GEL CAP | 04-29-36 | 04-29-36 | 1 |
| 5 | LUG, TERMINAL, COMPRESSION | 44-66-60 | 44-66-65 | 1 |

* WHEN CONNECTING BOTH LEGS OF 1/0 ALUMINUM TRIPLEX, DOUBLE QUANTITY OF MATERIAL EXCEPT FOR ITEM No. 5.

NOTES:

- FOR INFORMATION ON COMPRESSION TERMINAL LUGS, REFER TO DRAWING CD210-27.
- CONNECT TO SECONDARY GROUND BUSHING.
- REFER TO DRAWING CD310-3 FOR GEL CAP INSTALLATION INSTRUCTIONS.

SUPERCEDES ORIGINAL SEALED BY E. WIEBE ON 94-07-03

| | | | | | |
|--|-----------------|--|------------------|--|-----------|
| APPROVED | | REVISIONS | | MANITOBA HYDRO DISTRIBUTION STANDARDS | |
| ORIGINAL DRAWING SEALED BY J.J.D. RINGASH 18-03-05 | | 17-11 1 ADDED SHT 3 & 4, MOVED PREVIOUS INFO FROM SHT2 TO SHT4, ADDED NEW BOM WITH GELCAP, RESEALED | | <p align="center">STREET LIGHT CIRCUIT PROTECTED BY A 60A FUSE AT TRANSFORMER</p> | |
| | | | | | |
| DRAWN C.A. | CHECKED L.D. | DATE 17-10 | SHT 0002 of 4 | | REV 01 |

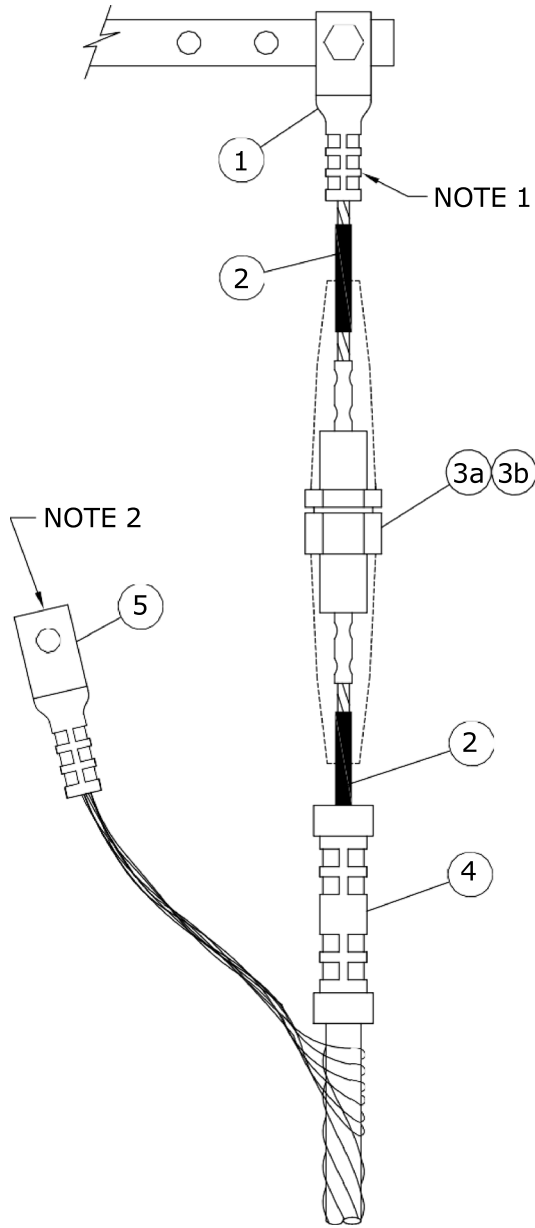

**No. 4 ALUMINUM
C/N CABLE**

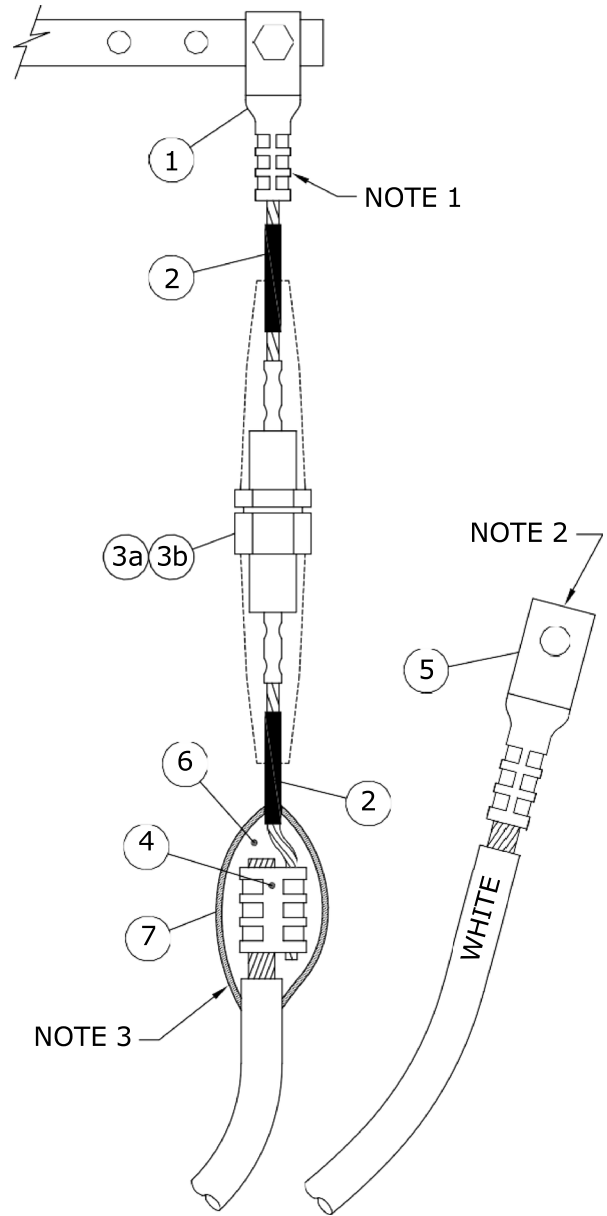

**1/0 ALUMINUM
TRIPLEX CABLE**

| | | | | |
|--|-----------------|---------------|--|--|
| APPROVED | REVISIONS | | MANITOBA HYDRO DISTRIBUTION STANDARDS | |
| ORIGINAL DRAWING SEALED BY J.J.D. RINGASH 18-03-05 | | | STREET LIGHT CIRCUIT PROTECTED BY A 60A FUSE AT TRANSFORMER | |
| | 17-11 | 0 | | |
| DRAWN C.A. | CHECKED L.D. | DATE 17-10 | CD 310-8 | |
| | | | | |

BILL OF MATERIAL

| ITEM No. | DESCRIPTION | STORES CODE No. | | QUANTITY * |
|----------|-----------------------------|-------------------------|------------------------------|------------|
| | | FOR USE WITH #4 AL. C/N | FOR USE WITH 1/0 AL. TRIPLEX | |
| 1 | LUG, TERMINAL, COMPRESSION | 44-66-63 | 44-66-63 | 1 |
| 2 | WIRE, # 6 CU., 600V, PVC | 93-10-06 | 93-10-06 | 1m |
| 3a | FUSEHOLDER, 60A C/W BOOTS | 31-91-60 | 31-91-60 | 1 |
| 3b | FUSE, STREET LIGHT, 60A | 31-14-60 | 31-14-60 | 1 |
| 4 | INSULATED SLEEVE | 74-45-50 | --- | 1 |
| | 'H' TYPE COMPRESSION TAP | --- | 74-40-30 | 1 |
| 5 | LUG, TERMINAL, COMPRESSION | 44-66-60 | 44-66-65 | 1 |
| 6 | TAPE, SELF-AMALGAMATING EPR | --- | 78-55-23 | 1/4 ROLL |
| 7 | TAPE, COLD WEATHER VINYL | --- | 78-55-98 | 1/4 ROLL |

* WHEN CONNECTING BOTH LEGS OF 1/0 ALUMINUM TRIPLEX, DOUBLE QUANTITY OF MATERIAL EXCEPT FOR ITEM No. 5.

NOTES:

- FOR INFORMATION ON COMPRESSION TERMINAL LUGS, REFER TO DRAWING CD210-27.
- CONNECT TO SECONDARY GROUND BUSHING.
- FOR PROPER TAPING PROCEDURE, REFER TO DRAWING CD215-12.

| | | | | | | | |
|--|--|-------------------------------|--|--|--|-----------|-----|
| APPROVED | | REVISIONS | | MANITOBA HYDRO DISTRIBUTION STANDARDS | | | |
| ORIGINAL DRAWING SEALED BY J.J.D. RINGASH 18-03-05 | | 17-11 0 MOVED FROM SHEET 2 | | <p align="center">STREET LIGHT CIRCUIT PROTECTED BY A 60A FUSE AT TRANSFORMER</p> | | | |
| | | | | | | | |
| | | | | <p align="center">CD 310-8</p> | | SHT | REV |
| | | | | | | 0004 of 4 | 00 |

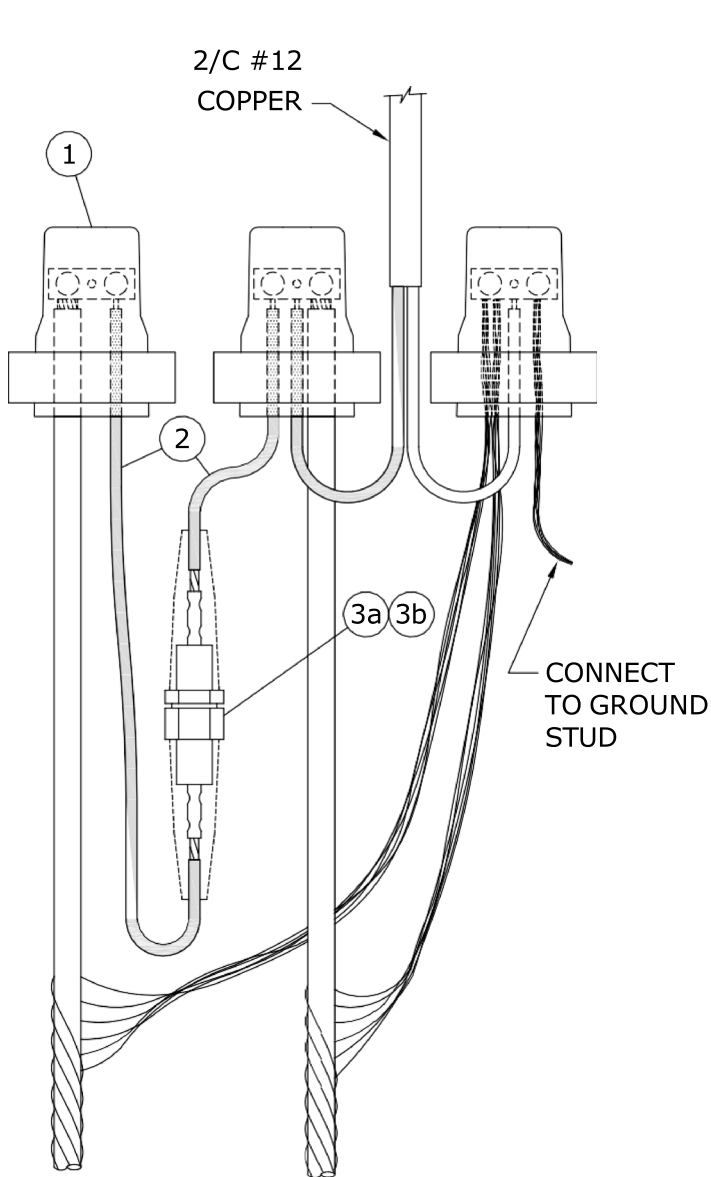

No. 4 ALUMINUM C/N CABLE

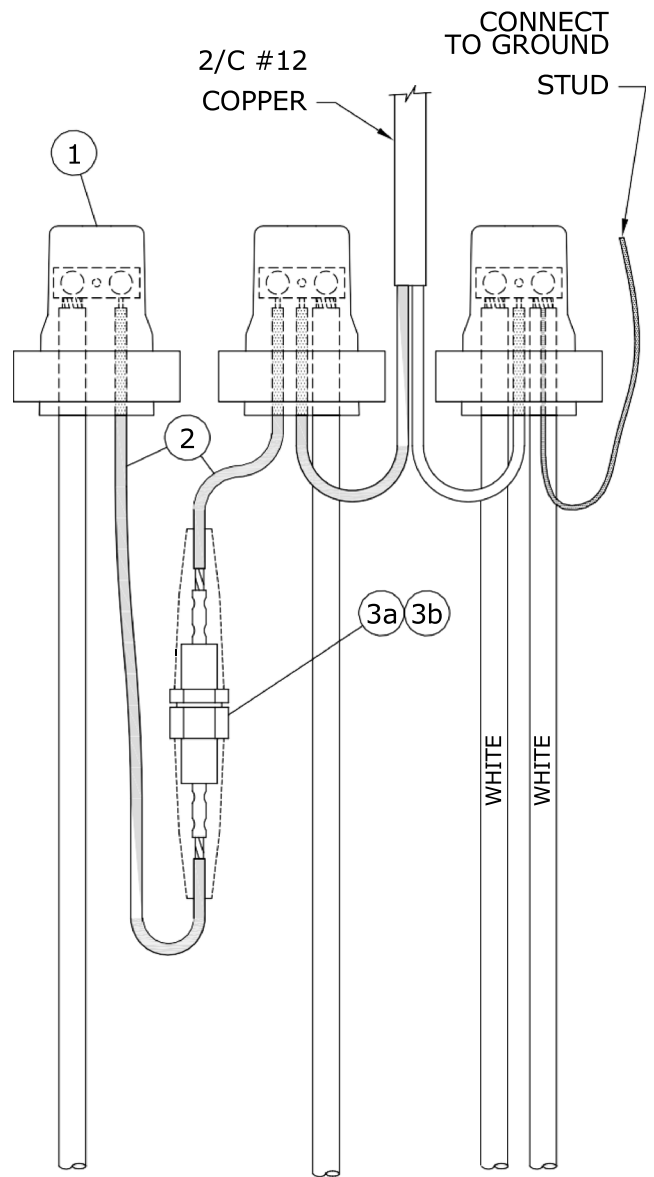

1/0 ALUMINUM TRIPLEX CABLE

SUPERCEDES ORIGINAL SEALED BY E. WIEBE ON 89-04-28

| | | | | | |
|--|-----------------|---------------|---|--|--|
| APPROVED | | REVISIONS | | MANITOBA HYDRO DISTRIBUTION STANDARDS | |
| ORIGINAL DRAWING SEALED BY J.J.D. RINGASH 18-03-05 | 17-11 | 2 | ADDED SHT 3 & 4, MOVED PREVIOUS INFO FROM SHT1 TO SHT3, ADDED NEW GELCAP, DWG, RESEALED | STREET LIGHT CIRCUIT PROTECTED BY 30A FUSE IN STREET LIGHT STANDARD | |
| | 94-04 | 1 | CONN. REVISED DUE TO INSUL. NEUTRAL | | |
| DRAWN C.A. | CHECKED L.D. | DATE 17-11 | | CD 310-9 | |
| | | | | | |

BILL OF MATERIAL

| ITEM No. | DESCRIPTION | STORES CODE No. | | QUANTITY |
|----------|------------------------------|-------------------------|------------------------------|----------|
| | | FOR USE WITH #4 AL. C/N | FOR USE WITH 1/0 AL. TRIPLEX | |
| 1 | GEL CAP | 04-29-36 | 04-29-36 | 3 |
| 2 | WIRE, # 8 CU., 600V, PVC | 93-10-08 | 93-10-08 | 1m |
| 3a | FUSEHOLDER, 15/30A C/W BOOTS | 31-91-30 | 31-91-30 | 1 |
| 3b | FUSE, 30A | 31-14-30 | 31-14-30 | 1 |

NOTES:

- 1. LEAVE SUFFICIENT SLACK ON CONDUCTORS AND FUSE HOLDER TO ALLOW REMOVAL FROM HANDHOLE FOR FUSE REPLACEMENT AND MAINTENANCE.**
2. FOR SPLICING FEED THROUGH HOT LEG, REFER TO DRAWING CD310-4.
3. FOR GEL CAP INSTALLATION INSTRUCTIONS, REFER TO DRAWING CD310-3.

SUPERCEDES ORIGINAL SEALED BY E. WIEBE ON 94-07-03

| | | | | | |
|--|--|--|--|--|--|
| APPROVED | | REVISIONS | | MANITOBA HYDRO DISTRIBUTION STANDARDS | |
| ORIGINAL DRAWING SEALED BY J.J.D. RINGASH 18-03-05 | | 17-11 1 ADDED SHT 3 & 4, MOVED PREVIOUS INFO FROM SHT2 TO SHT4, ADDED NEW BOM WITH GELCAP, RESEALED | | <p align="center">STREET LIGHT CIRCUIT PROTECTED BY 30A FUSE IN STREET LIGHT STANDARD</p> | |
| | | | | | |
| | | | | CD 310-9 | |

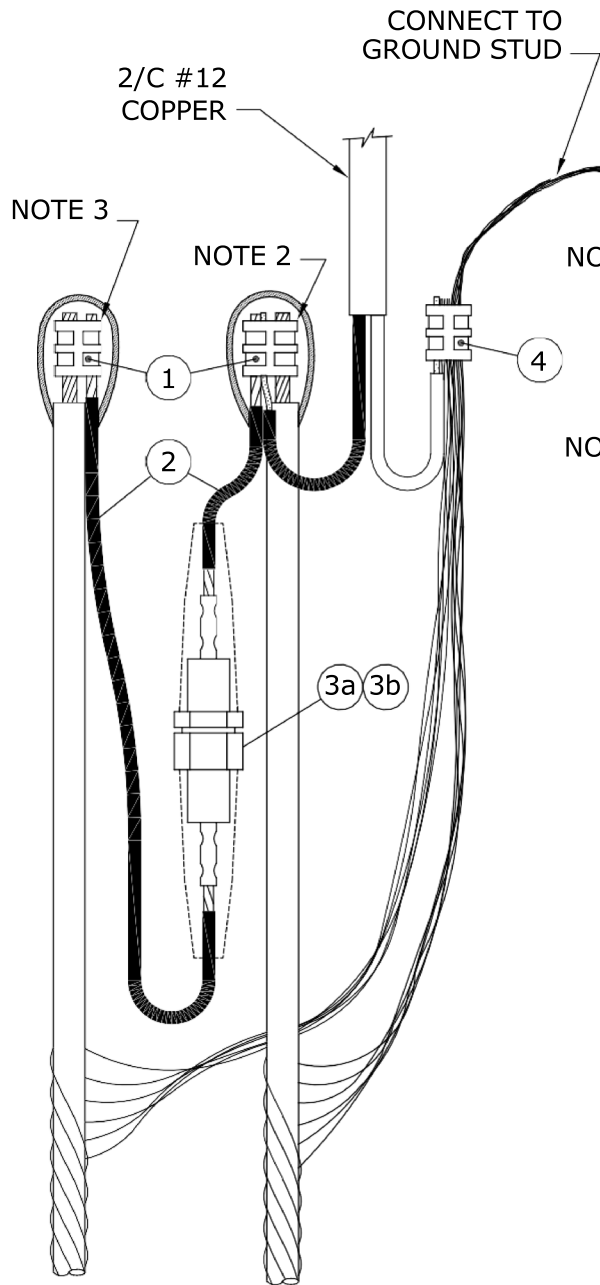

No. 4 ALUMINUM C/N CABLE

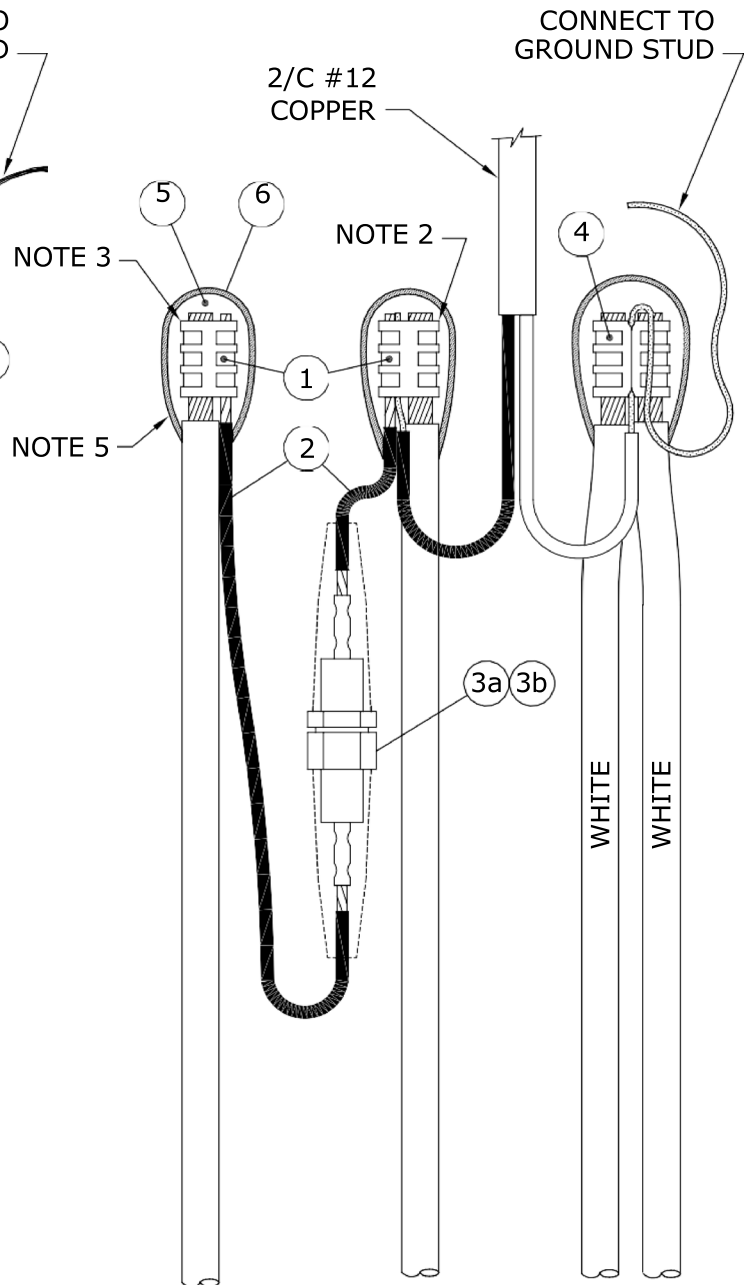

1/0 ALUMINUM TRIPLEX CABLE

| | | | | |
|--|-----------------|---------------|--|--|
| APPROVED | REVISIONS | | MANITOBA HYDRO DISTRIBUTION STANDARDS | |
| ORIGINAL DRAWING SEALED BY J.J.D. RINGASH 18-03-05 | | | STREET LIGHT CIRCUIT PROTECTED BY 30A FUSE IN STREET LIGHT STANDARD | |
| | 17-11 | 0 | | |
| DRAWN C.A. | CHECKED L.D. | DATE 17-11 | CD 310-9 | |
| | | | | |

BILL OF MATERIAL

| ITEM No. | DESCRIPTION | STORES CODE No. | | QUANTITY |
|----------|------------------------------|-------------------------|------------------------------|----------|
| | | FOR USE WITH #4 AL. C/N | FOR USE WITH 1/0 AL. TRIPLEX | |
| 1 | 'H' TYPE COMPRESSION TAP | 74-40-10 | 74-40-30 | 2 |
| 2 | WIRE, # 8 CU., 600V, PVC | 93-10-08 | 93-10-08 | 1m |
| 3a | FUSEHOLDER, 15/30A C/W BOOTS | 31-91-30 | 31-91-30 | 1 |
| 3b | FUSE, 30A | 31-14-30 | 31-14-30 | 1 |
| 4 | 'C' TYPE COMPRESSION TAP | 74-40-90 | --- | 1 |
| | 'H' TYPE COMPRESSION TAP | --- | 74-40-60 | 1 * |
| 5 | TAPE, SELF-AMALGAMATING EPR | 78-55-23 | 78-55-23 | 1/4 ROLL |
| 6 | TAPE, COLD WEATHER VINYL | 78-55-98 | 78-55-98 | 1/4 ROLL |

* WHEN USING 1/0 ALUMINUM TRIPLEX 1 ADDITIONAL 'H' TYPE COMPRESSION TAP (S.C.# 74 40 60) IS REQUIRED TO CONNECT SECOND (FEED THROUGH) HOT LEG.

NOTES:

- LEAVE SUFFICIENT SLACK ON CONDUCTORS AND FUSE HOLDER TO ALLOW REMOVAL FROM HANDHOLE FOR FUSE REPLACEMENT AND MAINTENANCE.**
- INSERT #12 COPPER AND #8 COPPER IN SMALL GROOVE.
- INSERT DOUBLE THICKNESS OF #8 COPPER IN SMALL GROOVE.
- FOR SPLICING FEED THROUGH HOT LEG, REFER TO DRAWING CD310-4.
- FOR PROPER TAPING PROCEDURE, REFER TO DRAWING CD215-12.

| | | | | | | | |
|--|-----------------|---------------|--|--|--|-----------|-----|
| APPROVED | | REVISIONS | | MANITOBA HYDRO DISTRIBUTION STANDARDS | | | |
| ORIGINAL DRAWING SEALED BY J.J.D. RINGASH 18-03-05 | | 17-11 0 | | <p align="center">STREET LIGHT CIRCUIT PROTECTED BY 30A FUSE IN STREET LIGHT STANDARD</p> | | | |
| | | | | | | | |
| DRAWN C.A. | CHECKED L.D. | DATE 17-11 | | CD 310-9 | | SHT | REV |
| | | | | | | 0004 of 4 | 00 |

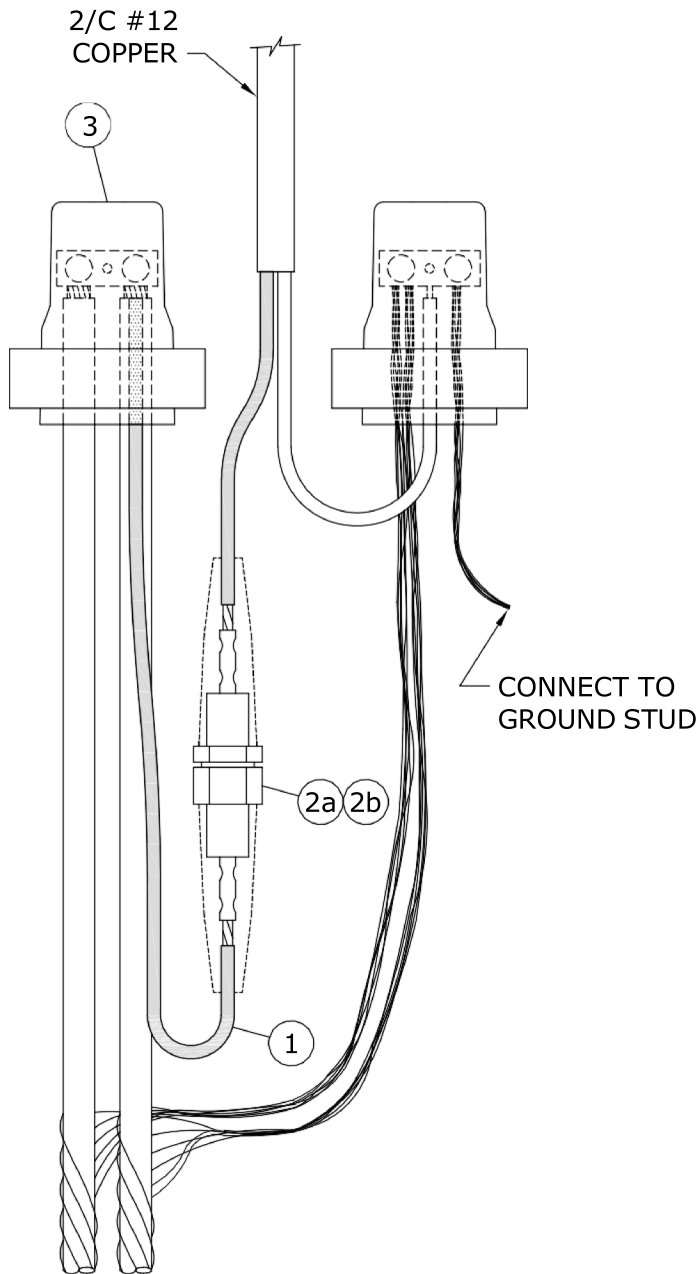

No. 4 ALUMINUM C/N CABLE

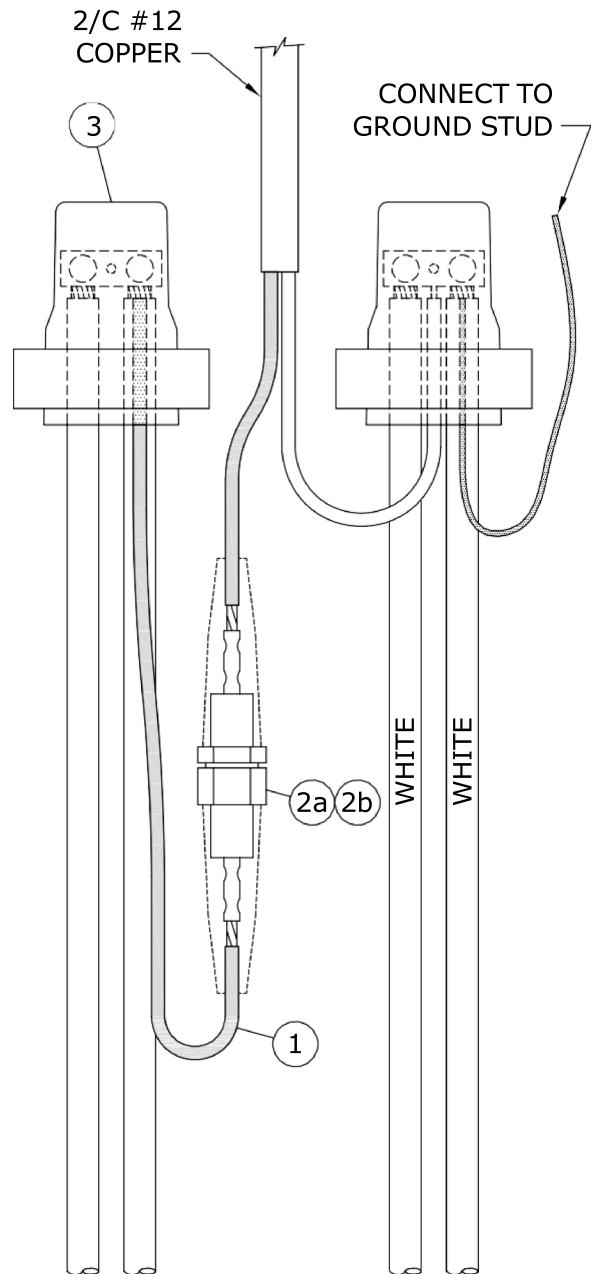

1/0 ALUMINUM TRIPLEX CABLE

NOTE:

RECOMMENDED FOR PROTECTING LUMINAIRES WHICH ARE TO BE MOUNTED ON STREET LIGHT POLES 16.8m AND HIGHER.

SUPERCEDES ORIGINAL SEALED BY E. WIEBE ON 89-04-28

| | | | | | |
|--|-----------------|---------------|---|--|------------------|
| APPROVED | | REVISIONS | | MANITOBA HYDRO DISTRIBUTION STANDARDS | |
| ORIGINAL DRAWING SEALED BY J.J.D. RINGASH 18-05-11 | 18-04 | 3 | ADDED SHT 3 & 4, MOVED PREVIOUS INFO FROM SHT1 TO SHT3, ADDED NEW GELCAP, DWG, RESEALED | INDIVIDUAL LUMINAIRE PROTECTED BY 15A FUSE IN STREET LIGHT STANDARD | |
| | 95-01 | 2 | NOTE ADDED | | |
| DRAWN C.A. | CHECKED L.D. | DATE 18-04 | CD 310-10 | | SHT 0001 of 4 |
| | | | | | REV 03 |

BILL OF MATERIAL

| ITEM No. | DESCRIPTION | STORES CODE No. | | QUANTITY |
|----------|------------------------------|-------------------------|------------------------------|----------|
| | | FOR USE WITH #4 AL. C/N | FOR USE WITH 1/0 AL. TRIPLEX | |
| 1 | 2/C #12 COPPER | 93-52-12 | 93-52-12 | 1m |
| 2a | FUSEHOLDER, 15/30A C/W BOOTS | 31-91-30 | 31-91-30 | 1 |
| 2b | FUSE, STREET LIGHT, 15A | 31-14-15 | 31-14-15 | 1 |
| 3 | GEL CAP | 04-29-36 | 04-29-36 | 2 |

NOTES:

- 1. LEAVE SUFFICIENT SLACK ON CONDUCTORS AND FUSE HOLDER TO ALLOW REMOVAL FROM HANDHOLE FOR FUSE REPLACEMENT AND MAINTENANCE.**
2. FOR SPLICING FEED THROUGH HOT LEG, REFER TO DRAWING CD310-4.
3. FOR END OF CIRCUIT, REFER TO DRAWING CD310-4.
4. FOR GEL CAP INSTALLATION INSTRUCTIONS, REFER TO DRAWING CD310-3.

SUPERCEDES ORIGINAL SEALED BY E. WIEBE ON 94-07-03

| | | | | | |
|--|-----------------|--|------------------|--|-----------|
| APPROVED | | REVISIONS | | MANITOBA HYDRO DISTRIBUTION STANDARDS | |
| ORIGINAL DRAWING SEALED BY J.J.D. RINGASH 18-05-11 | | 18-04 1 ADDED SHT 3 & 4, MOVED PREVIOUS INFO FROM SHT2 TO SHT4, ADDED NEW BOM WITH GELCAP, RESEALED | | <p align="center">INDIVIDUAL LUMINAIRE PROTECTED BY 15A FUSE IN STREET LIGHT STANDARD</p> | |
| | | | | | |
| DRAWN C.A. | CHECKED L.D. | DATE 18-04 | SHT 0002 of 4 | | REV 01 |

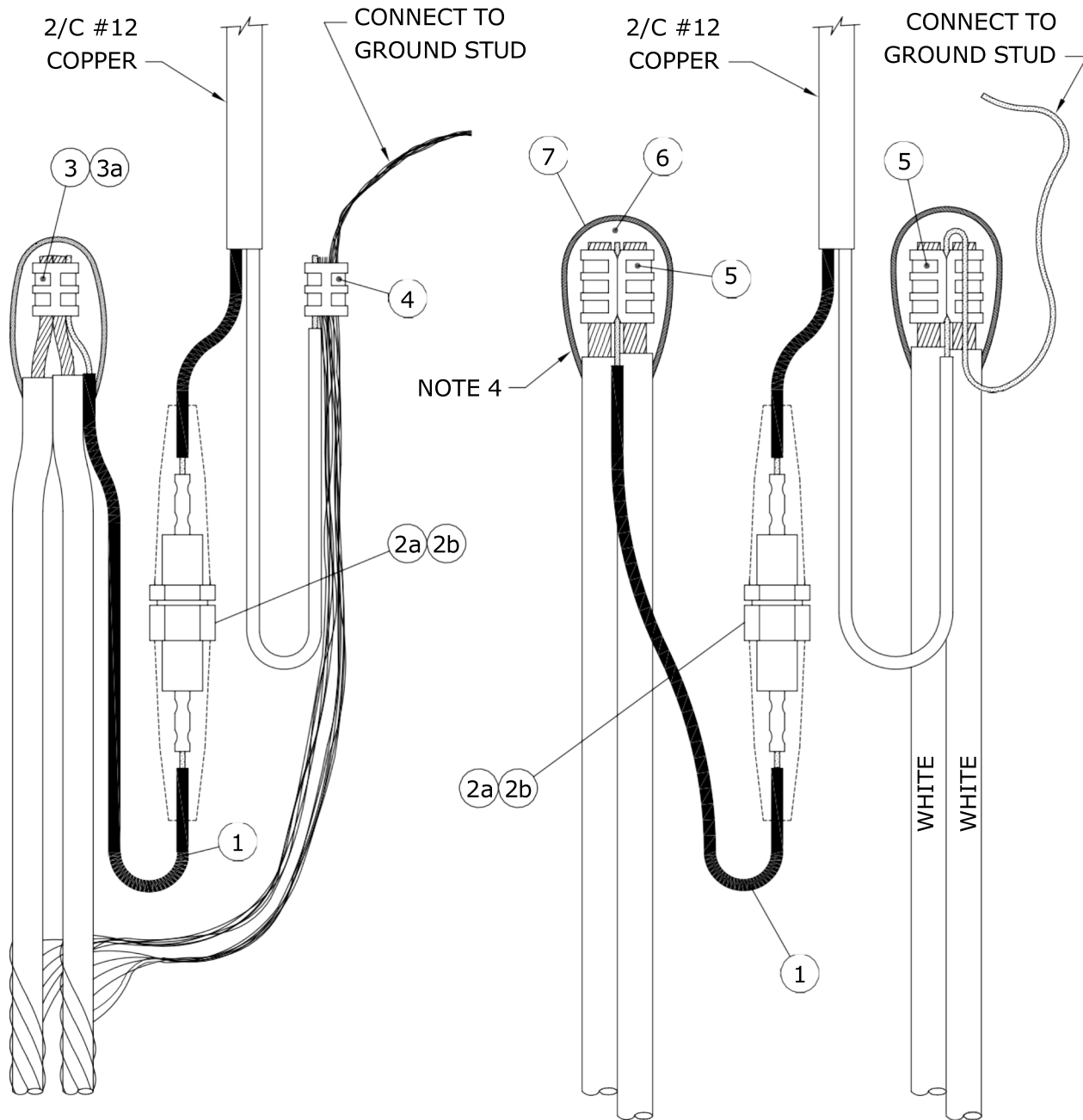

No. 4 ALUMINUM C/N CABLE

1/0 ALUMINUM TRIPLEX CABLE

NOTE:

RECOMMENDED FOR PROTECTING LUMINAIRES WHICH ARE TO BE MOUNTED ON STREET LIGHT POLES 16.8m AND HIGHER.

| | | | | |
|--|-----------------|---------------|--|--|
| APPROVED | REVISIONS | | MANITOBA HYDRO DISTRIBUTION STANDARDS | |
| ORIGINAL DRAWING SEALED BY J.J.D. RINGASH 18-05-11 | | | INDIVIDUAL LUMINAIRE PROTECTED BY 15A FUSE IN STREET LIGHT STANDARD | |
| | 18-04 | 0 | | |
| DRAWN C.A. | CHECKED L.D. | DATE 18-04 | CD 310-10 | |
| | | | | |

BILL OF MATERIAL

| ITEM No. | DESCRIPTION | STORES CODE No. | | QUANTITY |
|----------|------------------------------|-------------------------|------------------------------|----------|
| | | FOR USE WITH #4 AL. C/N | FOR USE WITH 1/0 AL. TRIPLEX | |
| 1 | 2/C # 12 COPPER | 93-52-12 | 93-52-12 | 1m |
| 2a | FUSEHOLDER, 15/30A C/W BOOTS | 31-91-30 | 31-91-30 | 1 |
| 2b | FUSE, STREET LIGHT, 15A | 31-14-15 | 31-14-15 | 1 |
| 3 | 'C' TYPE AL. COMPRESSION TAP | 74-41-30 | --- | 1 |
| 3a | 'H' TYPE AL. COMPRESSION TAP | 74-40-10 | --- | 1 * |
| 4 | 'C' TYPE CU. COMPRESSION TAP | 74-40-90 | --- | 1 |
| 5 | 'H' TYPE AL. COMPRESSION TAP | --- | 74-40-60 | 3 ** |
| 6 | TAPE, SELF-AMALGAMATING EPR | 78-55-23 | 78-55-23 | 1/4 ROLL |
| 7 | TAPE, COLD WEATHER VINYL | 78-55-98 | 78-55-98 | 1/4 ROLL |

- * FOR END OF CIRCUIT WHEN USING ONLY ONE CABLE.
- ** AT END OF CIRCUIT, QUANTITY MAY BE LESS THAN SHOWN.

NOTES:

1. **LEAVE SUFFICIENT SLACK ON CONDUCTORS AND FUSE HOLDER TO ALLOW REMOVAL FROM HANDHOLE FOR FUSE REPLACEMENT AND MAINTENANCE.**
2. FOR SPLICING FEED THROUGH HOT LEG, REFER TO DRAWING CD310-4.
3. FOR END OF CIRCUIT, REFER TO DRAWING CD310-4.
4. FOR PROPER TAPING PROCEDURE, REFER TO DRAWING CD215-12.

| | | | | | | | |
|--|-----------------|---------------|--|--|--|-----------|-----|
| APPROVED | | REVISIONS | | MANITOBA HYDRO DISTRIBUTION STANDARDS | | | |
| ORIGINAL DRAWING SEALED BY J.J.D. RINGASH 18-05-11 | | 18-04 0 | | <p align="center">INDIVIDUAL LUMINAIRE PROTECTED BY 15A FUSE IN STREET LIGHT STANDARD</p> | | | |
| | | | | | | | |
| DRAWN C.A. | CHECKED L.D. | DATE 18-04 | | CD 310-10 | | SHT | REV |
| | | | | | | 0004 of 4 | 00 |

SUPPLY VOLTAGES

THE SUPPLY VOLTAGE FOR STREET LIGHT CIRCUITS MAY BE PROVIDED BY POLE-MOUNTED DISTRIBUTION TRANSFORMERS OR BY PAD-MOUNTED DISTRIBUTION TRANSFORMERS.

THE MAJORITY OF ROADWAY LUMINAIRES ARE RATED FOR OPERATION ON EITHER 120 VOLT OR 240 VOLT CIRCUITS AND ARE FACTORY WIRED FOR 120 VOLT OPERATION EXCEPT FOR 400 WATT H.P.S. LUMINAIRES WHICH ARE RATED FOR 120/240 VOLT OPERATION BUT ARE FACTORY WIRED FOR 240 VOLT OPERATION.

IN CASES WHERE EXCESSIVE VOLTAGE DROP IN A STREET LIGHTING CIRCUIT IS A PROBLEM, A SUPPLY VOLTAGE OF 240/480 MAY BE USED. A SUPPLY VOLTAGE OF 240/480 CAN BE OBTAINED FROM TWO SINGLE PHASE POLE-MOUNTED DISTRIBUTION TRANSFORMERS CONNECTED AS SHOWN ON DRAWING CD315-2. IF A SINGLE PHASE PAD-MOUNTED DISTRIBUTION TRANSFORMER WITH A 240/480 VOLT SECONDARY IS REQUIRED, THE TRANSFORMER MUST BE ORDERED FROM THE MANUFACTURER (SEE DRAWING CD315-2).

CAUTION:

PRIOR TO CONNECTING LUMINAIRES TO A 240 VOLT SUPPLY CIRCUIT IT IS IMPORTANT TO CHECK THE INTERNAL CONNECTIONS TO THE TERMINAL BLOCK TO ENSURE THAT THE UNIT IS PROPERLY CONNECTED FOR 240 VOLT OPERATION.

| | | | | |
|--|-----------------|---------------|--|-----------|
| APPROVED | REVISIONS | | MANITOBA HYDRO DISTRIBUTION STANDARDS | |
| ORIGINAL DRAWING SEALED BY E.H. WIEBE 89-04-28 | | | SUPPLY VOLTAGES FOR STREET LIGHT CIRCUITS | |
| DRAWN W.B./CAD | CHECKED W.C. | DATE 88-08 | CD 315-1 | |
| | | | SHT 0001 of 1 | REV 00 |

NOTE:

1. X2 SECONDARY GROUNDING STRAP MUST BE REMOVED.

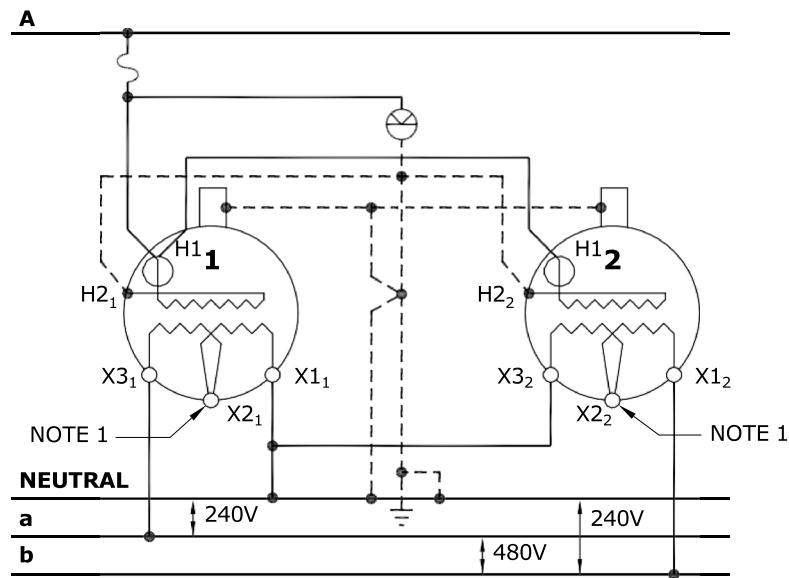

SECONDARY VOLTAGE 240/480V GROUNDED. TWO SINGLE-PHASE POLE-MOUNTED TRANSFORMERS WITH 120/240V SECONDARIES.

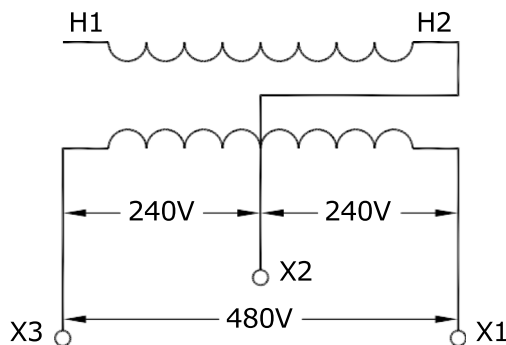

SECONDARY VOLTAGE 240/480V GROUNDED. SINGLE-PHASE PAD-MOUNTED TRANSFORMER AS SUPPLIED BY MANUFACTURER

SAFETY PRECAUTION

1. SINGLE PHASE PAD MOUNTED TRANSFORMERS WITH ABOVE SECONDARY VOLTAGES TO HAVE WARNING SIGN "**CAUTION - 240/480V SECONDARY - SEE NAMEPLATE**", STENCILLED ON THE OUTSIDE OF THE TRANSFORMER NEAR NAMEPLATE.
2. NAMEPLATES OF MODIFIED TRANSFORMERS TO BE REVISED.

PURCHASE OF 240/480 VOLT TRANSFORMER

1. INCLUDE ABOVE WARNING SIGN REQUIREMENT IN PURCHASE DESCRIPTION.

SUPERCEDES ORIGINAL SEALED BY E. WIEBE ON 89-04-28

| | | | | | |
|--|----------------------|---------------|---------------------------|--|------------------|
| APPROVED | | REVISIONS | | MANITOBA HYDRO DISTRIBUTION STANDARDS | |
| ORIGINAL DRAWING SEALED BY J.J.D. RINGASH 21-06-09 | 21-06 | 3 | ADDED NOTE 1, RESEALED | 240/480 VOLT SUPPLY FOR STREET LIGHT CIRCUITS | |
| | 13-01 | 2 | REVISED DIAGRAM | | |
| | 90-04 | 1 | DROPOUT DELETED | | |
| DRAWN C.A. | CHECKED D.F./L.D. | DATE 21-06 | CD 315-2 | | SHT 0001 of 1 |
| | | | | | REV 03 |

CONTROL METHODS

1. LUMINAIRES CONTROLLED INDIVIDUALLY BY PHOTO-ELECTRIC CELL

THE PREFERRED METHOD FOR PROVIDING ON/OFF CONTROL OF A STREET LIGHT LUMINAIRE IS TO INSTALL A PHOTO-ELECTRIC CELL ON EACH LUMINAIRE, IF LUMINAIRES ARE MOUNTED ON HIGHER POLES (IN EXCESS OF 10.7 M OR 35 FT.) WHERE IT IS DIFFICULT TO REACH THE LUMINAIRE WITH THE LOCAL DISTRICT BUCKET TRUCK, CONSIDERATION SHOULD BE GIVEN TO USING A PHOTO-ELECTRIC CONTROLLED EXTERNALLY-MOUNTED RELAY SYSTEM.

2. PHOTO-ELECTRIC CONTROLLED EXTERNALLY-MOUNTED RELAY

SEVERAL LUMINAIRES CAN BE CONTROLLED SIMULTANEOUSLY BY INSTALLING A PHOTO-ELECTRIC CONTROLLED, EXTERNALLY MOUNTED RELAY, ON A WOOD POLE (SEE CD315-11) OR ON A STEEL STREET LIGHT POLE (SEE CD315-12). SINGLE POLE (SINGLE CIRCUIT) RELAYS ARE AVAILABLE WITH EITHER A 30 AMP OR A 60 AMP RATING. A BY-PASS SWITCH MAY BE INSTALLED TO PROVIDE A MEANS OF ACTIVATING THE STREET LIGHT CIRCUIT FOR DAYLIGHT MAINTENANCE PURPOSES.

3. STREET LIGHT RELAY USING STREET LIGHT CONTROL

ACTIVATING SUCCESSIVE SECTIONS OF STREET LIGHTING CIRCUITS BY MEANS OF A SERIES OF RELAYS (KNOWN AS A CASCADE CONTROLLED SYSTEM) IS NO LONGER USED AS A CONTROL METHOD. HOWEVER, SOME CASCADE CONTROLLED RELAY SYSTEMS REMAIN IN SERVICE. THE CONNECTION DIAGRAMS FOR A CASCADE CONTROLLED RELAY SYSTEM ARE SHOWN ON DRAWING CD315-14. DOUBLE POLE (DOUBLE CIRCUIT) RELAYS ARE NO LONGER PURCHASED, THEREFORE, DOUBLE POLE RELAYS WHICH FAIL MUST BE REPLACED WITH TWO SINGLE POLE RELAYS. BOTH THE SINGLE AND DOUBLE POLE OLDER STYLE RELAYS HAVE A 5 AMP FUSE PROTECTING THE RELAY COIL.

4. STREET LIGHT RELAY USING PILOT WIRE CONTROL

PILOT WIRE CONTROL SYSTEMS ARE NO LONGER USED FOR NEW CONSTRUCTION. HOWEVER, SOME PILOT WIRE CONTROL SYSTEMS REMAIN IN SERVICE. THE CONNECTION DIAGRAMS FOR PILOT WIRE CONTROL SYSTEMS ARE SHOWN ON DRAWING CD315-15. DOUBLE POLE (DOUBLE CIRCUIT) RELAYS ARE NO LONGER PURCHASED. THEREFORE, DOUBLE POLE RELAYS WHICH FAIL MUST BE REPLACED WITH TWO SINGLE POLE RELAYS.

5. PHOTO-ELECTRIC CONTROLLED RELAY IN BASE OF STANDARD

COMPACT RELAYS, MOUNTED IN THE BASE OF STEEL STREET LIGHT STANDARDS ARE NO LONGER USED FOR NEW CONSTRUCTION. THE COMPACT RELAY IS ACTIVATED VIA THE PHOTO-ELECTRIC CONTROLLER ON THE LUMINAIRE. IF A COMPACT RELAY FAILS AN EXTERNALLY-MOUNTED RELAY AND PHOTO-ELECTRIC CONTROLLER SHOULD BE INSTALLED (SEE CD315-12 AND CD315-13).

| | | | | | |
|--|-----------------|---------------|--|-----------|------------------|
| APPROVED | REVISIONS | | MANITOBA HYDRO DISTRIBUTION STANDARDS | | |
| ORIGINAL DRAWING SEALED BY E.H. WIEBE 89-04-28 | | | CONTROL METHODS FOR STREET LIGHT CONTROLS | | |
| DRAWN W.B./CAD | CHECKED W.C. | DATE 88-08 | CD 315-10 | | SHT 0001 of 1 |
| | | | | REV 00 | |

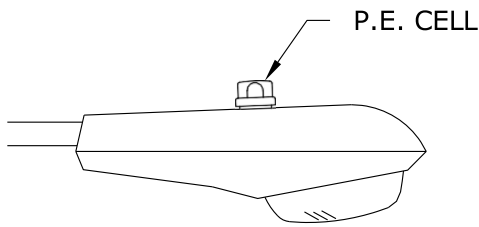

INDIVIDUALLY CONTROLLED LUMINAIRE

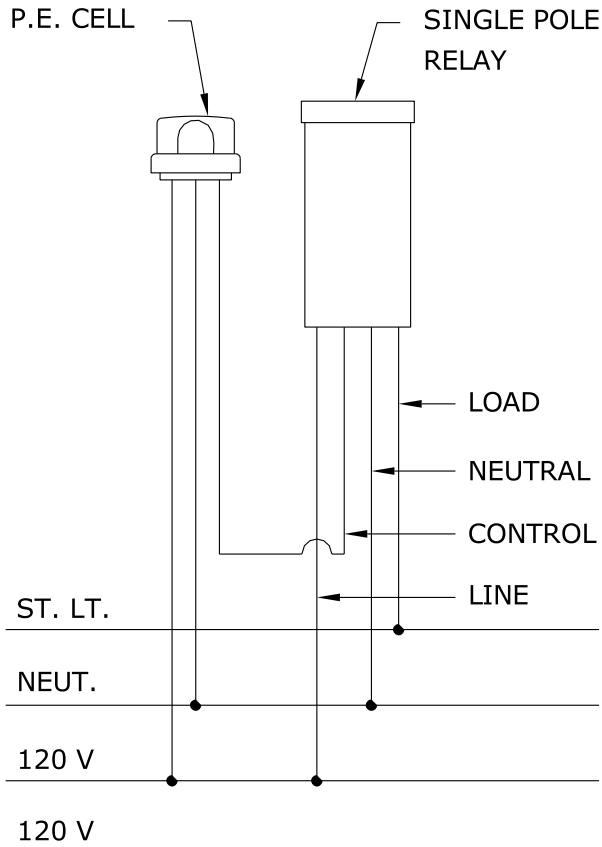

SINGLE POLE (SINGLE CIRCUIT) RELAY CONNECTIONS

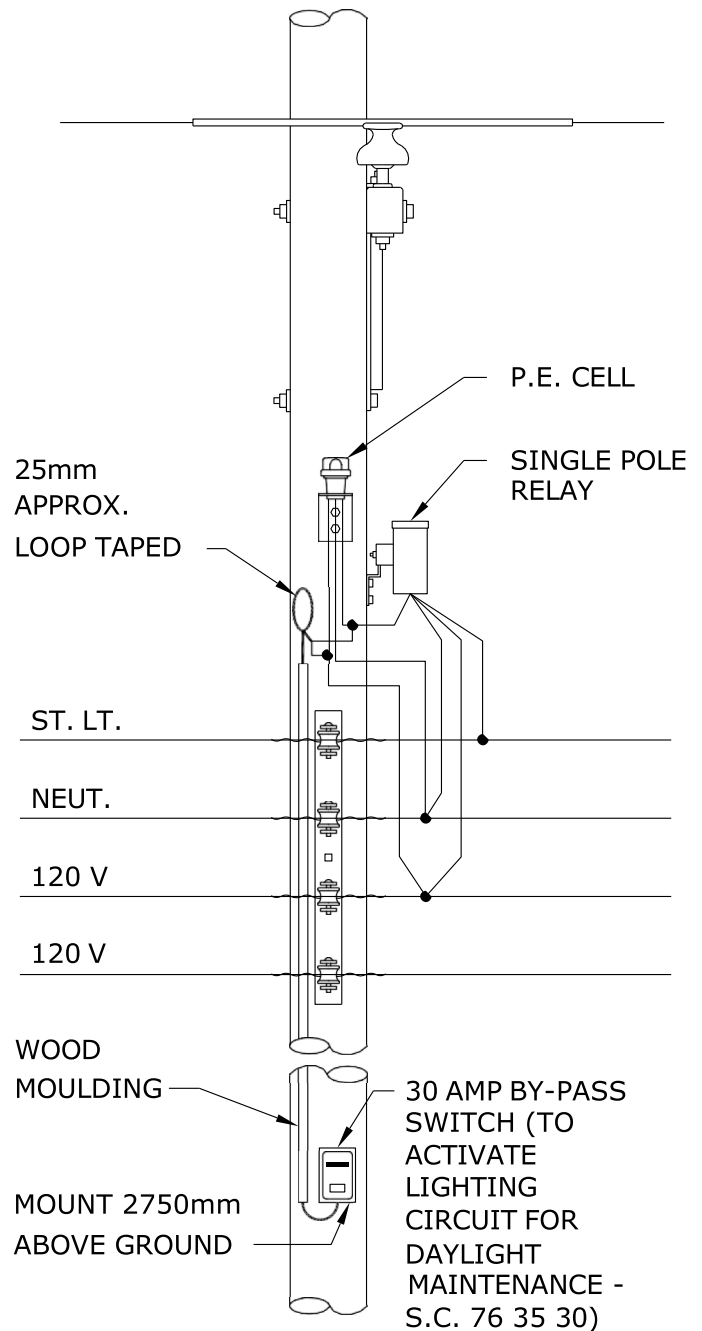

SINGLE POLE (SINGLE CIRCUIT) RELAY C/W BY-PASS SWITCH

NOTE:
P.E. CELL MUST BE MOUNTED SO THAT CELL WINDOW FACES NORTH.

| | | | | | |
|--|--------------|------------|---------------|--|--|
| APPROVED | | REVISIONS | | MANITOBA HYDRO DISTRIBUTION STANDARDS | |
| ORIGINAL DRAWING SEALED BY E.H. WIEBE 89-04-28 | | | | <p>PHOTO-ELECTRIC CELL, RELAY AND BY-PASS SWITCH CONNECTION DIAGRAM</p> <p>CD 315-11</p> | |
| DRAWN W.B./CAD | CHECKED W.C. | DATE 88-09 | SHT 0001 of 1 | | |

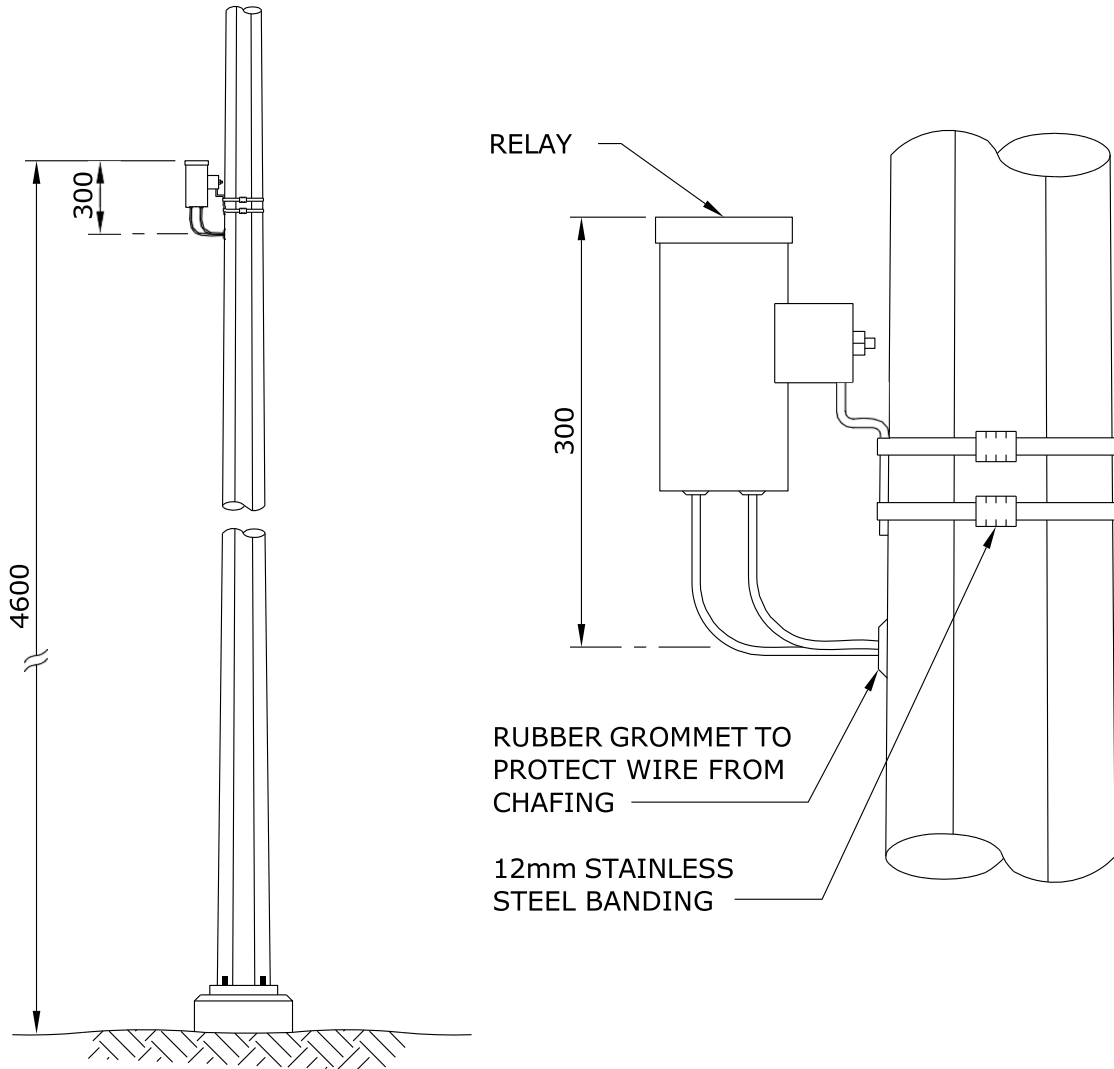

NOTES:

1. DRILL 25mm HOLE AT A POINT 4.3m ABOVE FINISHED GRADE.
2. INSTALL RUBBER GROMMET IN HOLE.
3. BAND RELAY TO POLE USING 12mm STAINLESS STEEL BANDING MATERIAL SO THAT THE TOP OF THE RELAY IS 300mm ABOVE THE CENTRE OF THE HOLE.
4. CONNECT RELAY LEADS TO 4.3m LENGTHS OF EQUAL SIZED CONDUCTOR AND PUSH SPLICES INSIDE POLE.
5. TAPE EXPOSED RELAY LEADS INTO A BUNDLE.
6. DIMENSIONS SHOWN ARE MILLIMETRES.

| | | | | | | | | | |
|--|-----------------|---------------|------------------|---|--|-----|-----|-----------|----|
| APPROVED | | REVISIONS | | MANITOBA HYDRO DISTRIBUTION STANDARDS | | | | | |
| ORIGINAL DRAWING SEALED BY E.H. WIEBE 89-04-28 | | | | INSTALLATION OF EXTERNALLY-MOUNTED RELAY | | | | | |
| DRAWN W.B./CAD | CHECKED W.C. | DATE 88-09 | CD 315-12 | | <table border="1"> <tr> <td>SHT</td> <td>REV</td> </tr> <tr> <td>0001 of 1</td> <td>00</td> </tr> </table> | SHT | REV | 0001 of 1 | 00 |
| SHT | REV | | | | | | | | |
| 0001 of 1 | 00 | | | | | | | | |

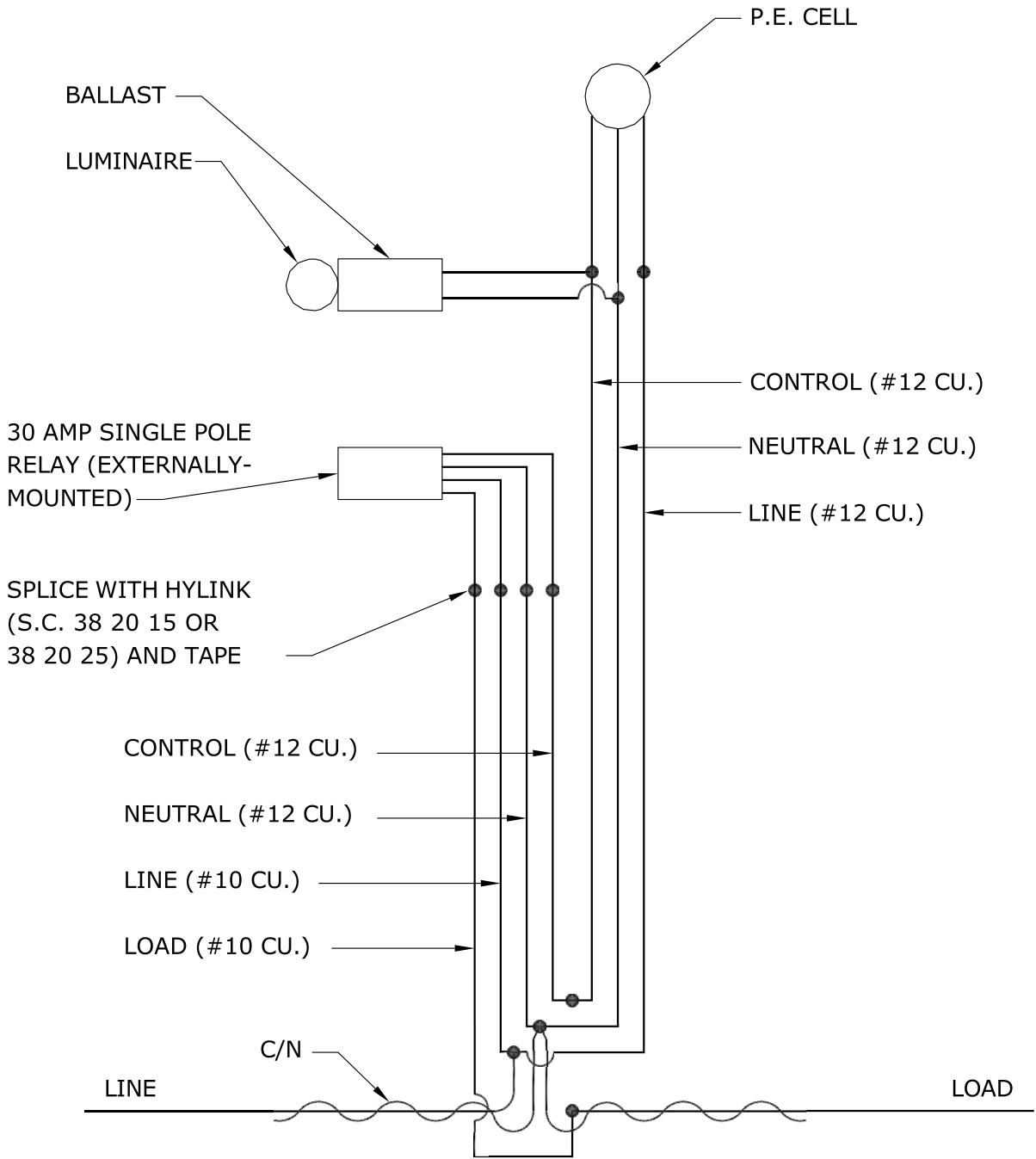

| | | | | | |
|--|-----------------|---------------|---|--|-----------|
| APPROVED | | REVISIONS | | MANITOBA HYDRO DISTRIBUTION STANDARDS | |
| ORIGINAL DRAWING SEALED BY E.H. WIEBE 89-04-28 | | | | CONNECTION SCHEMATIC FOR EXTERNALLY-MOUNTED RELAY | |
| | | 94-03 | 1 | | |
| DRAWN W.B./CAD | CHECKED W.C. | DATE 88-09 | | CD 315-13 | |
| | | | | SHT 0001 of 1 | REV 01 |

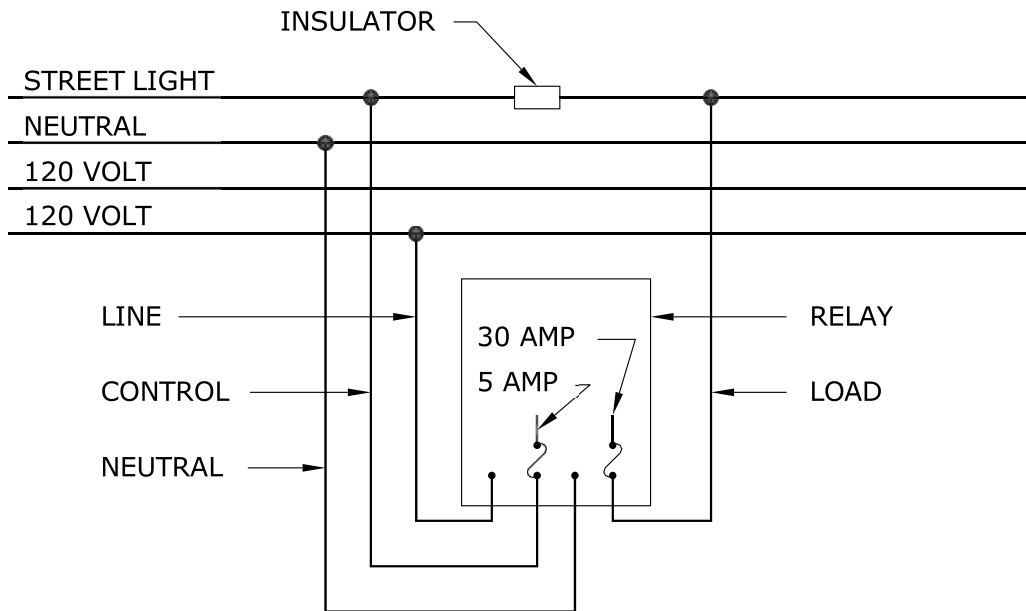

SINGLE POLE (SINGLE CIRCUIT) RELAY

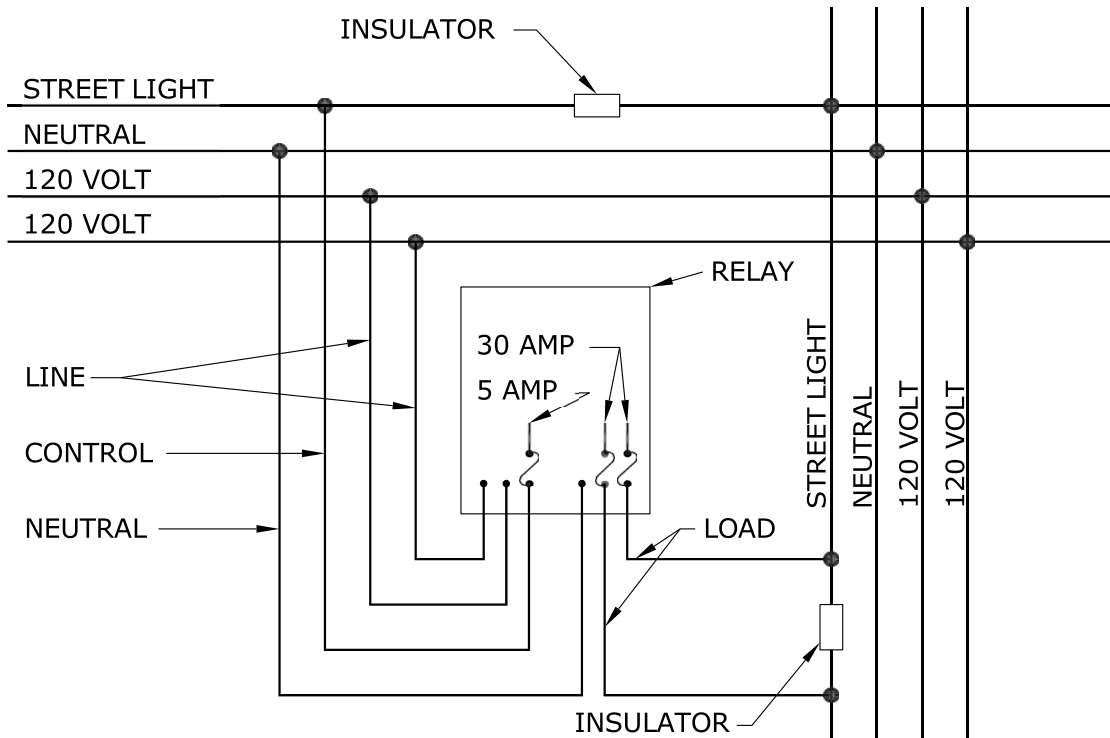

DOUBLE POLE (DOUBLE CIRCUIT) RELAY

NOTE:
 CASCADE SYSTEM NOT USED FOR NEW CONSTRUCTION.

| | | | | | | | | | |
|--|-----------------|---------------|------------------|---|--|-----|-----|-----------|----|
| APPROVED | | REVISIONS | | MANITOBA HYDRO DISTRIBUTION STANDARDS | | | | | |
| ORIGINAL DRAWING SEALED BY E.H. WIEBE 89-04-28 | | | | STREET LIGHT RELAY CONNECTIONS USING STREET LIGHT CONTROL (CASCADE SYSTEM) | | | | | |
| DRAWN W.B./CAD | CHECKED W.C. | DATE 88-09 | CD 315-14 | | <table border="1"> <tr> <td>SHT</td> <td>REV</td> </tr> <tr> <td>0001 of 1</td> <td>00</td> </tr> </table> | SHT | REV | 0001 of 1 | 00 |
| SHT | REV | | | | | | | | |
| 0001 of 1 | 00 | | | | | | | | |

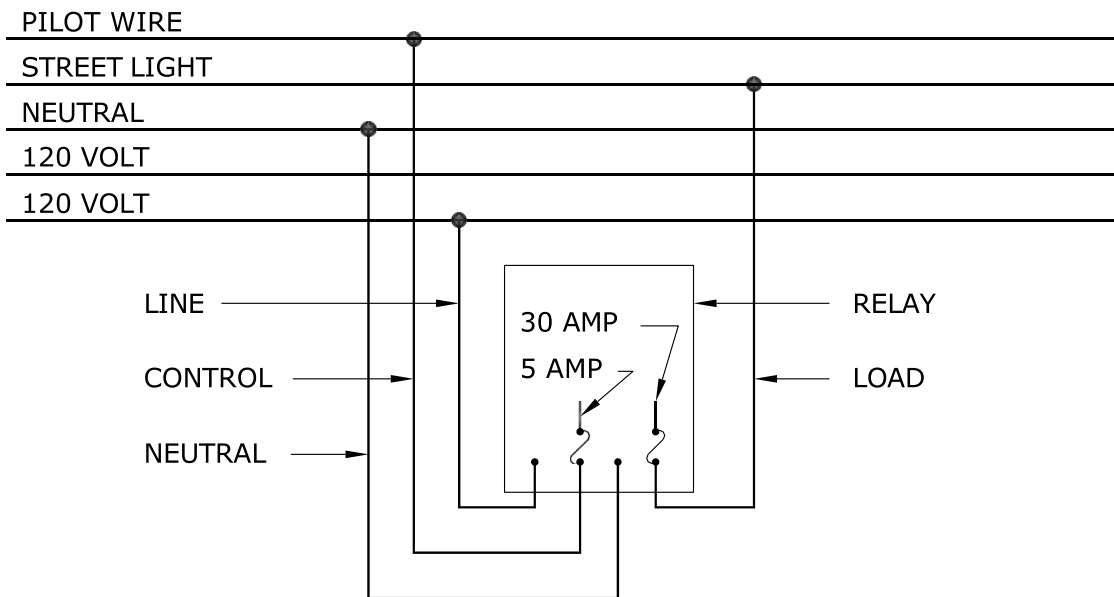

SINGLE POLE (SINGLE CIRCUIT) RELAY

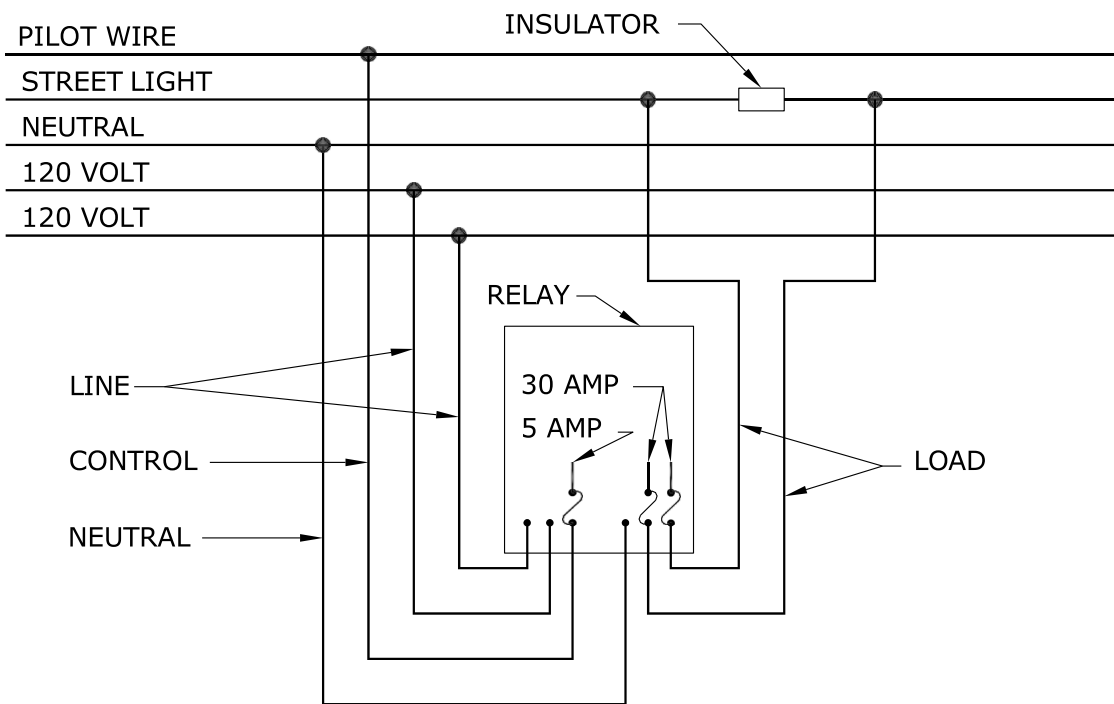

DOUBLE POLE (DOUBLE CIRCUIT) RELAY

NOTE:

PILOT WIRE SYSTEMS NOT USED FOR NEW CONSTRUCTION.

| | | | | | | | | | |
|--|-----------------|---------------|------------------|--|--|-----|-----|-----------|----|
| APPROVED | | REVISIONS | | MANITOBA HYDRO DISTRIBUTION STANDARDS | | | | | |
| ORIGINAL DRAWING SEALED BY E.H. WIEBE 89-04-28 | | | | STREET LIGHT RELAY CONNECTIONS USING PILOT WIRE | | | | | |
| DRAWN W.B./CAD | CHECKED W.C. | DATE 88-09 | CD 315-15 | | <table border="1"> <tr> <td>SHT</td> <td>REV</td> </tr> <tr> <td>0001 of 1</td> <td>00</td> </tr> </table> | SHT | REV | 0001 of 1 | 00 |
| SHT | REV | | | | | | | | |
| 0001 of 1 | 00 | | | | | | | | |

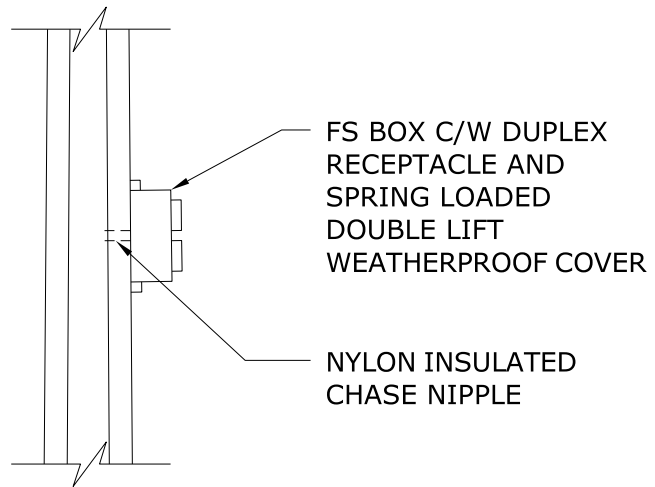
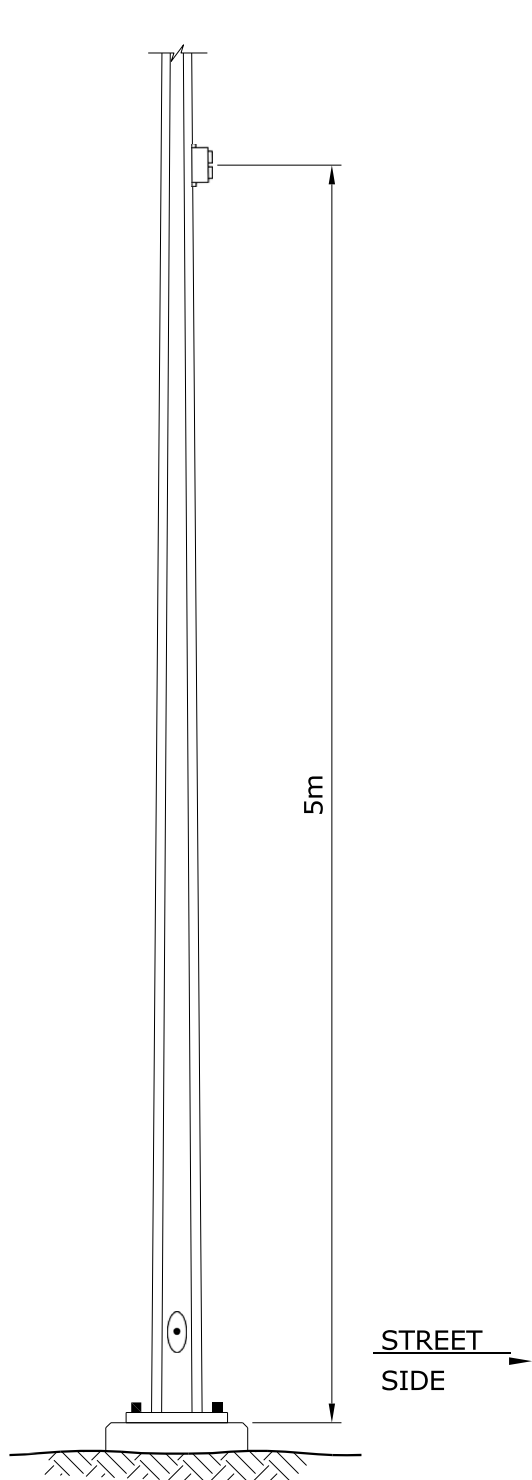

NOTES:

1. DRILL 30mm (1 1/8") DIA. HOLE 5 METRES ABOVE BASE OF POLE.
2. INSTALL 30A INLINE FUSEHOLDER FUSED AT 15A.
3. IF INSTALLED ON A CONTROLLED STREET LIGHT CIRCUIT, CONDUCTORS TO BE CONNECTED VIA RECEPTACLE TO LUMINAIRE.
4. IF INSTALLED ON AN UNCONTROLLED STREET LIGHT CIRCUIT, CONDUCTORS TO BE CONNECTED TO LUMINAIRE. RECEPTACLE TO BE CONNECTED TO P.E. CELL NEUTRAL AND CONTROL WIRES IN LUMINAIRE.
5. CONDUCTORS TO BE 2/C #12 PVC STREET LIGHT CABLE.
6. PUBLIC AUTHORITY MUST BE ADVISED AS TO MAXIMUM LOAD WHICH MAY BE CONNECTED TO RECEPTACLE.

| | | | | | |
|--|--|-----------------------|--|---|--|
| APPROVED | | REVISIONS | | MANITOBA HYDRO DISTRIBUTION STANDARDS | |
| ORIGINAL DRAWING SEALED BY E.H. WIEBE 89-04-28 | | 13-01 1 ADDED SHEET 2 | | DECORATIVE LIGHTING RECEPTACLE INSTALLED ON STEEL POLE | |
| | | | | | |
| | | DATE 88-09 | | CD 315-24 | |
| | | | | SHT 0001 of 2 | |
| | | | | REV 01 | |

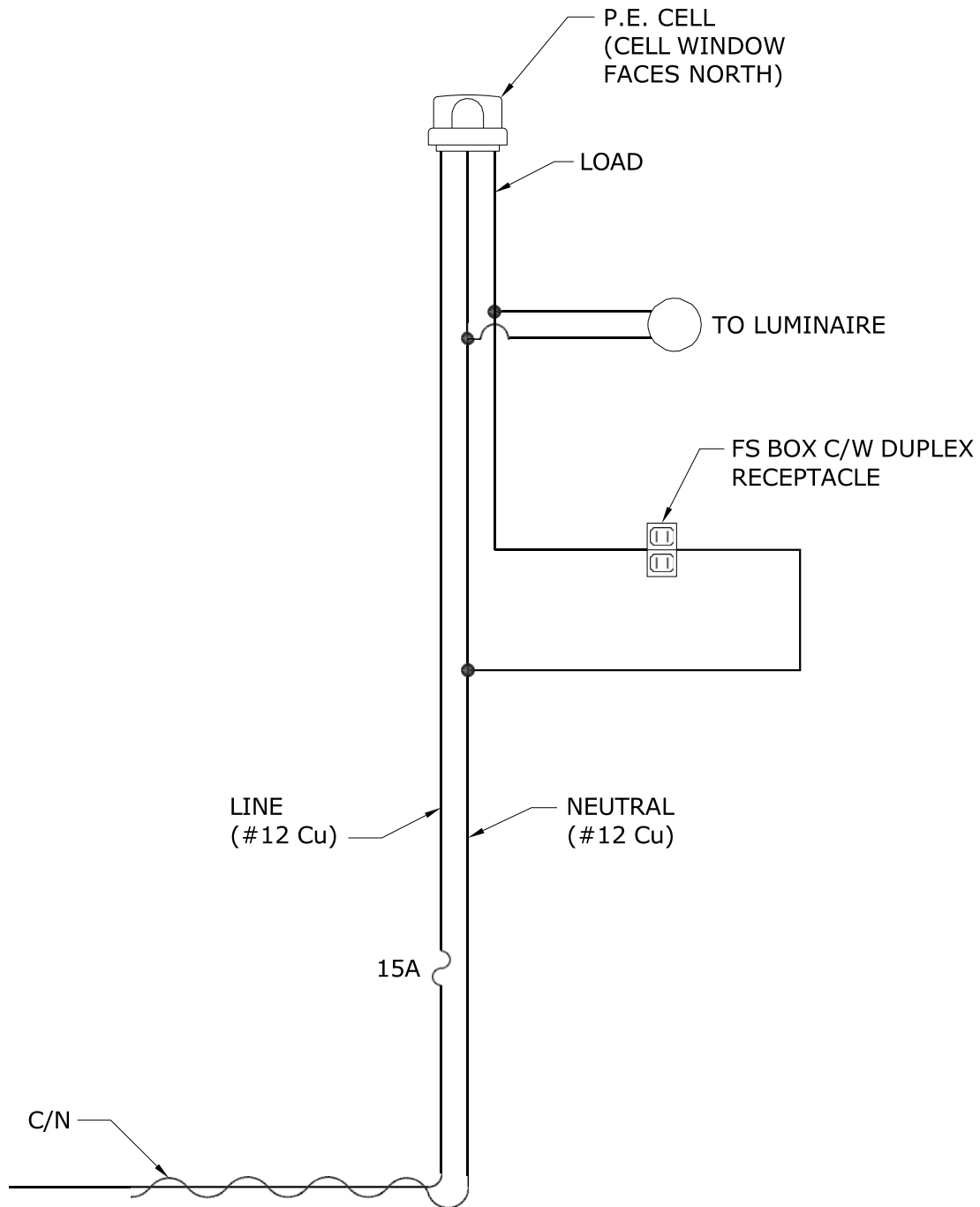

TYPICAL CONNECTION DIAGRAM

| | | | | | | | | | |
|--|-----------------|---------------|------------------|---|--|-----|-----|-----------|----|
| APPROVED | | REVISIONS | | MANITOBA HYDRO DISTRIBUTION STANDARDS | | | | | |
| ORIGINAL DRAWING SEALED BY D.R. ORR 13-02-12 | | | | DECORATIVE LIGHTING RECEPTACLE INSTALLED ON STEEL POLE | | | | | |
| DRAWN C.A. | CHECKED L.D. | DATE 13-01 | CD 315-24 | | <table border="1"> <tr> <td>SHT</td> <td>REV</td> </tr> <tr> <td>0002 of 2</td> <td>00</td> </tr> </table> | SHT | REV | 0002 of 2 | 00 |
| SHT | REV | | | | | | | | |
| 0002 of 2 | 00 | | | | | | | | |

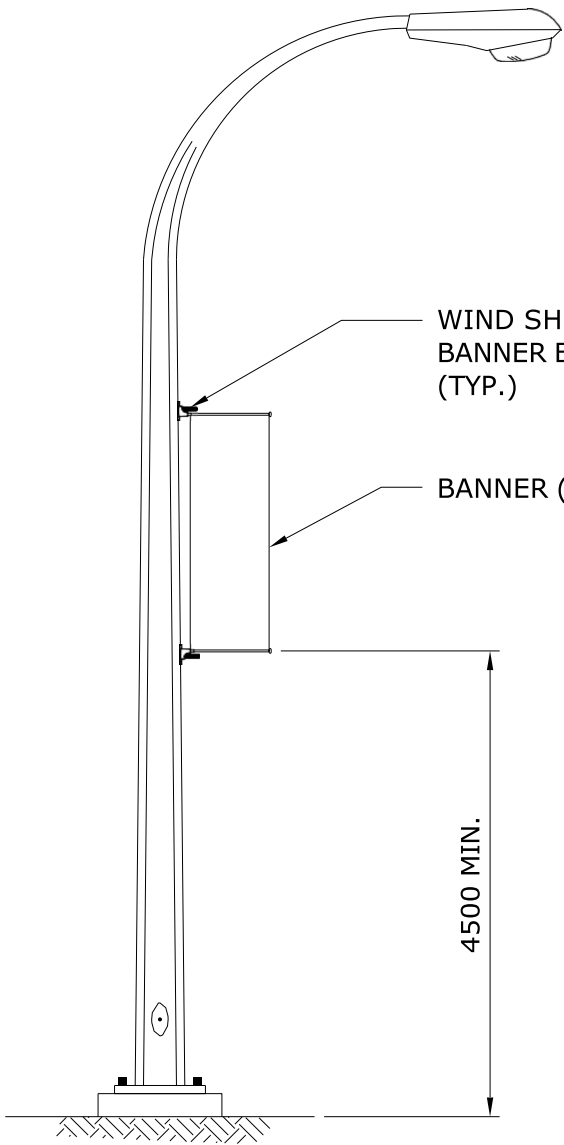

WIND SHEDDING
BANNER BRACKET
(TYP.)

BANNER (TYP.)

4500 MIN.

SINGLE BANNER INSTALLATION
(762mm X 2286mm MAXIMUM
DIMENSION)

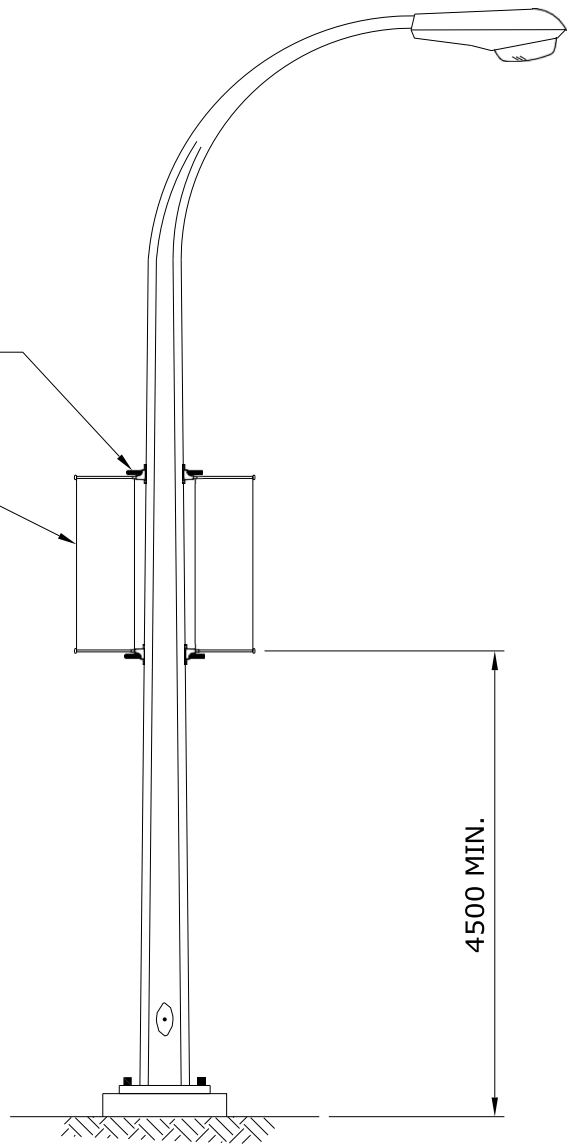

DOUBLE BANNER INSTALLATION
(559mm X 1676mm MAXIMUM
DIMENSION)

NOTE: DIMENSIONS SHOWN ARE IN MILLIMETRES.

| | | | | |
|---|----------------------|---------------|--|-----------|
| APPROVED | REVISIONS | | MANITOBA HYDRO DISTRIBUTION STANDARDS | |
| ORIGINAL DRAWING SEALED BY K.C. HAMILTON 07-06-29 | | | BANNER INSTALLATION DETAILS | |
| | 13-01 | 1 | | |
| DRAWN C.A. | CHECKED L.D./D.O. | DATE 07-06 | CD 315-25 | |
| | | | SHT 0001 of 3 | REV 01 |

BANNER CRITERIA:

1. BANNER INSTALLATION TO CONSIST UP TO A MAXIMUM SIZE OF EITHER ONE 762mm x 2286mm (30"x90") CLOTH BANNER, OR TWO 559mm x 1676mm (22"x66") CLOTH BANNERS.
2. BANNERS CAN BE ORIENTED EITHER 90° OR 180° FROM EACH OTHER AROUND CIRCUMFERENCE OF STANDARD FOR DOUBLE BANNER INSTALLATIONS.
3. BANNER INSTALLATION SHALL NOT IMPEDE WIND SHEDDING CHARACTERISTICS OF BANNER MOUNTING BRACKET.
4. APPROVAL OF STANDARDS FOR BANNER MOUNTING TO BE BASED UPON:
 - a. A SATISFACTORY ASSESSMENT OF THE STANDARDS STRUCTURAL INTEGRITY AND IT'S FOUNDATION PER CORPORATE POLICY P348-4, "MAINTAINING OUTDOOR LIGHTING - ORNAMENTAL LIGHT STANDARDS REPLACEMENT GUIDE", AND P348-5, "MAINTAINING OUTDOOR LIGHTING - REPLACING OR RESETTING CONCRETE FOUNDATIONS".
 - b. TIGHTENING OR REPLACING ANY LOOSE OR MISSING ANCHOR NUTS OR BOLTS.
 - c. AN UNIMPEDED DRIVER'S VIEW OF TRAFFIC SIGNALS OR TRAFFIC CONTROL SIGNAGE.
 - d. NOT EXCEEDING THE STANDARD'S MAXIMUM ALLOWABLE SIGNAGE SURFACE AREA WHERE STANDARD HAS EXISTING SIGNAGE, SEE NOTE 5.
5. IF BANNER(S) ARE TO BE INSTALLED ON STANDARDS WITH EXISTING SIGNAGE, THE MAXIMUM ALLOWABLE BANNER SIZE (SURFACE AREA) MOUNTED WITH WIND-SHEDDING BRACKETS CAN BE CALCULATED WITH THE FOLLOWING FORMULA:

| |
|---|
| $\text{MAXIMUM SURFACE AREA OF BANNER(S) (m}^2\text{)*} = 1.75 \times \left(1 - \frac{\text{SURFACE AREA OF SIGNAGE (m}^2\text{)}}{\text{SURFACE AREA OF SIGNAGE (m}^2\text{)}} \right)$ |
|---|

* DIVIDE BY 2 FOR DOUBLE BANNER INSTALLATION.

| | | | | |
|---|----------------------|---------------|--|-----------|
| APPROVED | REVISIONS | | MANITOBA HYDRO DISTRIBUTION STANDARDS | |
| ORIGINAL DRAWING SEALED BY K.C. HAMILTON 07-06-29 | | | BANNER INSTALLATION DETAILS | |
| 13-01 | 1 | REVISED TITLE | | |
| DRAWN C.A. | CHECKED L.D./D.O. | DATE 07-06 | CD 315-25 | |
| | | | SHT 0002 of 3 | REV 01 |

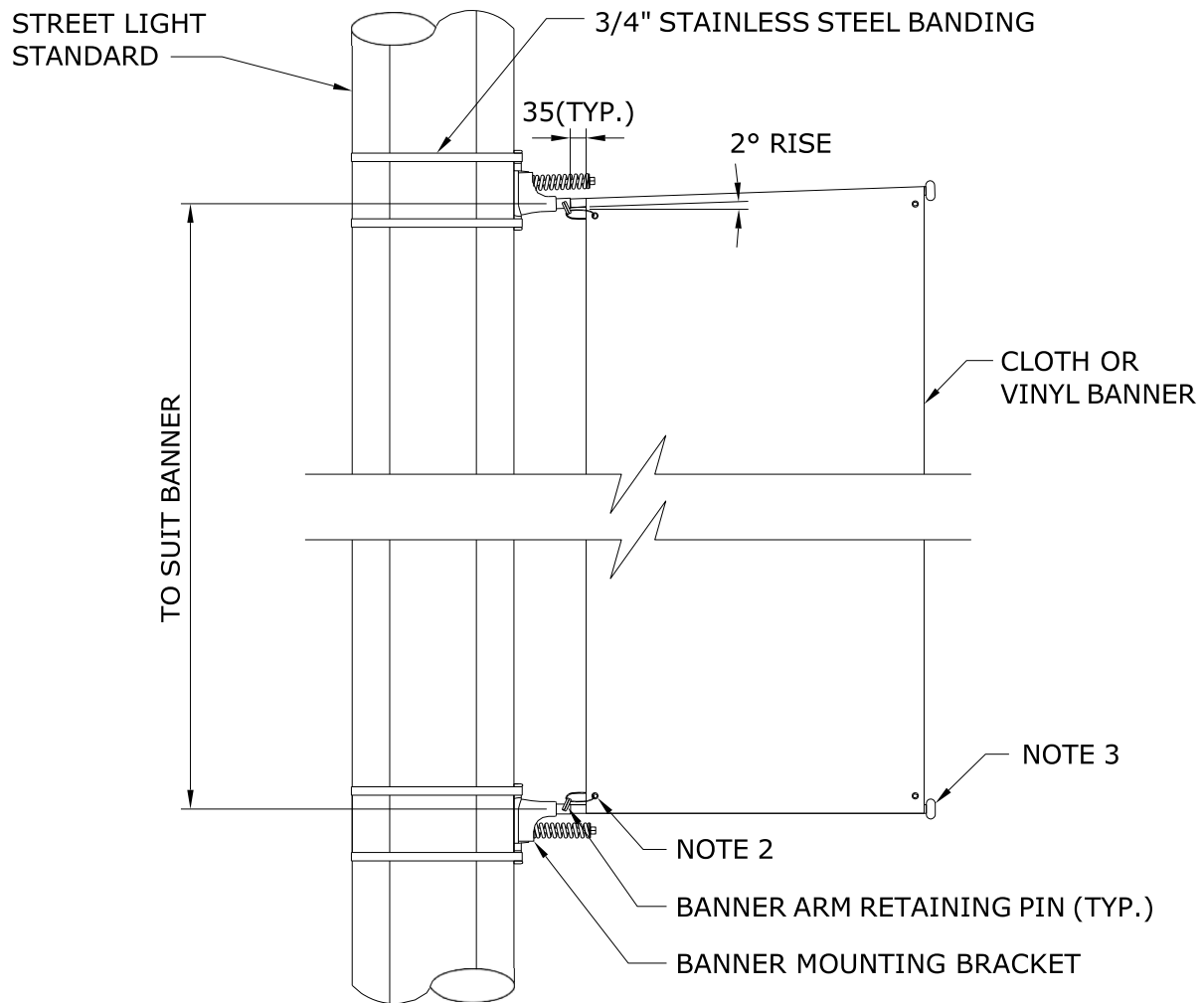

NOTES:

1. CUSTOMER TO COMPLETE AN APPLICATION FOR USE OF MANITOBA HYDRO UTILITY POLES (EFORM #H1900) AND HAVE FORM APPROVED PRIOR TO INSTALLATION OF BANNERS AND ASSOCIATED EQUIPMENT.
2. BANNER TO HAVE REINFORCED HOLES. SECURE BANNER TO BRACKET WITH U.V. RESISTANT TY-RAPS (2 LOCATIONS PER BANNER). LOOP TY-RAP THROUGH REINFORCED HOLE AND EYELET OF BANNER ARM RETAINING PIN.
3. 3/4"Ø FIBREGLASS ROD. CUT TO SUIT BANNER.
4. BANNER MOUNTING BRACKET AND ARM TO BE WIND SHEDDING TYPE.
5. INSTALL BANNER MOUNTING BRACKETS SO BANNER IS TAUT ACROSS LENGTH OF BANNER ROD.
6. DIMENSIONS SHOWN ARE MILLIMETRES.

| | | | | | |
|---|----------------------|---------------|------------------|--|------------------|
| APPROVED | | REVISIONS | | MANITOBA HYDRO DISTRIBUTION STANDARDS | |
| ORIGINAL DRAWING SEALED BY K.C. HAMILTON 07-06-29 | | | | BANNER INSTALLATION DETAILS | |
| | | 13-01 | 1 | | |
| DRAWN C.A. | CHECKED L.D./D.O. | DATE 07-06 | CD 315-25 | | SHT 0003 of 3 |
| | | | | | REV 01 |

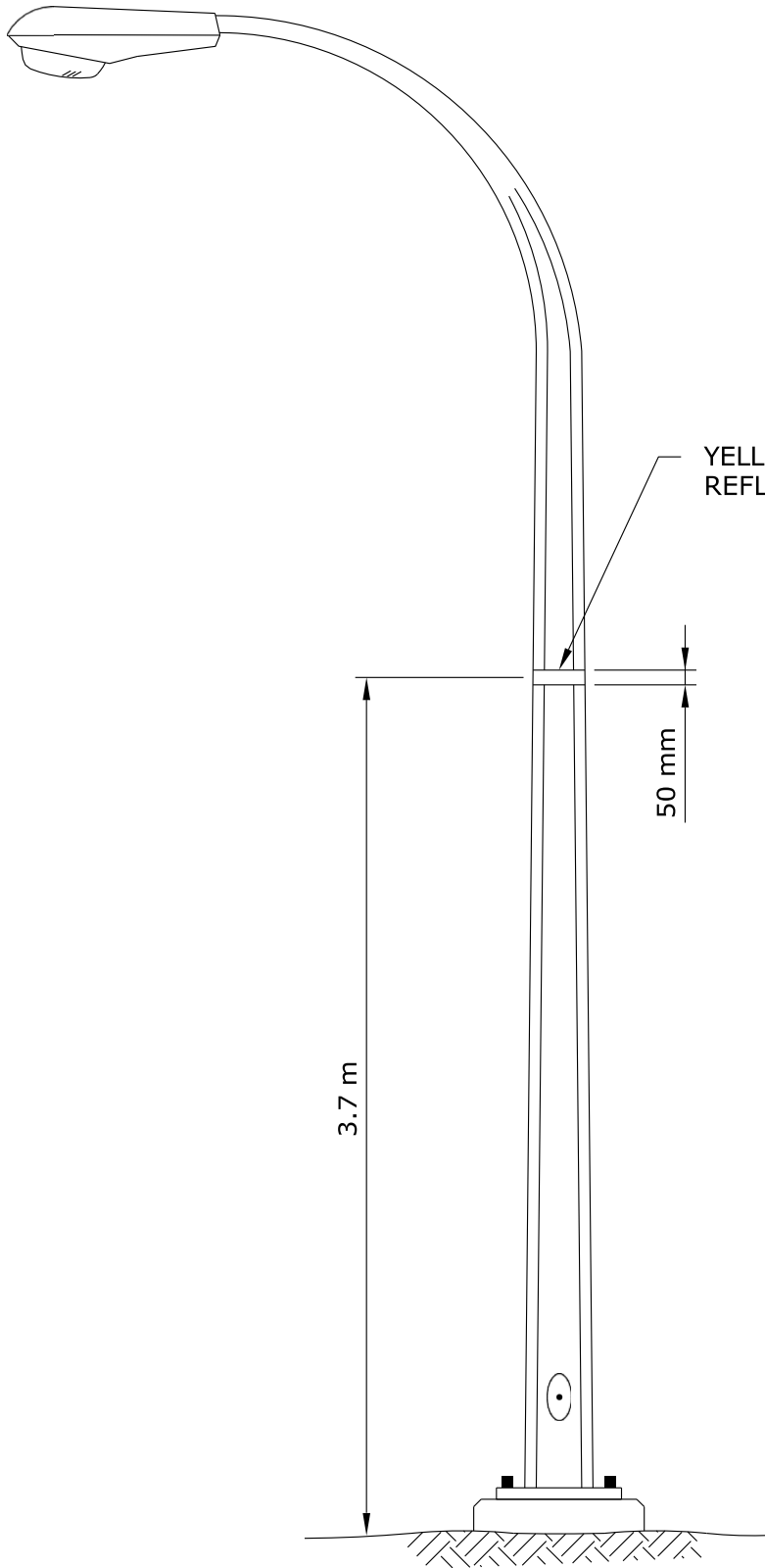

YELLOW SCOTCHLITE
REFLECTIVE TAPE

50 mm

3.7 m

| | | | | | |
|--|-----------------|---------------|------------------|--|-----|
| APPROVED | | REVISIONS | | MANITOBA HYDRO DISTRIBUTION STANDARDS | |
| ORIGINAL DRAWING SEALED BY E.H. WIEBE 89-04-28 | | | | IDENTIFICATION OF FIRST STREET LIGHT STANDARD CONNECTION TO CIRCUIT | |
| DRAWN W.B./CAD | CHECKED W.C. | DATE 88-09 | CD 315-35 | | |
| | | | SHT | | REV |
| | | | 0001 of 1 | | 00 |